

# SOFT POWER



Prior to use, please read this user's manual carefully.

CAUTION: Please keep this user's manual for future reference.

# CONTENTS

CONTENTS .....	1
Chapter 1. About this manual.....	2
Chapter 2. Solar pumping system introduction.....	5
Chapter 3. Solar pump drive overview .....	7
Chapter 4. Operation control panel description .....	14
Chapter 5. Solar pump drive installation .....	16
Chapter 6. Solar pump drive commissioning guide .....	18
Chapter 7. Simple parameter list .....	20
Chapter 8. Parameters description in detail .....	42
Chapter 9. Troubleshooting and Countermeasures .....	46
Appendix. Solar arrays selecting list. ....	48

# Chapter 1. About this manual

This chapter provides an overview of the contents, purpose, compatibility, and the intended audience of this manual. The solar pump drive is an enhancement of the drive firmware. This supplement manual intends to serve as a quick start guide for installing, commissioning and operating the solar pump inverter. This manual includes all the required parameter settings and program features specific to the solar pump drive.

## READ AND FOLLOW ALL INSTRUCTIONS!

When installing and using this electrical equipment, basic safety precautions should always be followed, including the following:



WARNING – To reduce the risk of injury, do not permit children to use this product unless they are closely supervised at all times.



WARNING – To reduce the risk of electric shock, replace damaged cord immediately.



WARNING – It must be assured that all grounding connections are properly made and that the resistances do meet local codes or requirements

This chapter provides an overview of the contents, purpose, compatibility, and the intended audience of this manual. The solar pump drive is an enhancement of the drive firmware. This supplement manual intends to serve as a quick start guide for installing, commissioning and operating the solar pump inverter. This manual includes all the required parameter settings and program features specific to the solar pump drive.

## READ AND FOLLOW ALL INSTRUCTIONS!

When installing and using this electrical equipment, basic safety precautions should always be followed, including the following:



WARNING – To reduce the risk of injury, do not permit children to use this product unless they are closely supervised at all times.



WARNING – To reduce the risk of electric shock, replace damaged cord immediately.



WARNING – It must be assured that all grounding connections are properly made and that the resistances do meet local codes or requirements

## Safety and cautions

### 1.1 General Warnings

The manual contains basic instructions which must be observed during installation, operation and maintenance. The manual should be carefully read before installation and start-up by the person in charge of the installation. The manual should also be read by all other technical personnel/ operators and should be available at the installation site at all times.

**Personnel Qualification and Training** – All personnel for the operation, maintenance, inspection and installation must be fully qualified to perform that type of job. Responsibility, competence and the supervision of such personnel must be strictly regulated by the user.

Should the available personnel be lacking the necessary qualification, they must be trained and instructed accordingly. If necessary, the operator may require the manufacturer/supplier to provide such training.

Furthermore the operator/user must make sure that the personnel fully understand the contents of the manual.

**Dangers of Ignoring the Safety Symbols** – Ignoring the safety directions and symbols may pose a danger to humans as well as to the environment and the equipment itself. Non-observance may void any warranties.

Non-observance of safety directions and symbols may for example cause the following: Failure of important functions of the equipment/plant; failure of prescribed methods for maintenance and repair; endangerment of persons through electrical, mechanical and chemical effects; danger to the environment because of leakage of hazardous material; danger of damage to equipment and buildings.

**Safety-oriented Operation** – The safety directions contained in the manual, existing national regulations for the prevention of accidents as well as internal guidelines and safety-regulations for the operator and user must be observed at all times.

**General Safety Directions for the Operator/User**– If hot or cold equipment parts pose a danger then they must be protected by the operator/user against contact with people. Protective covers for moving parts (e.g. couplings) must not be removed when the equipment is running. Leaks (e.g. at the shaft seal) of hazardous pumping media (e.g. explosive, toxic, hot liquids) must be disposed of in such a way that any danger to personnel and the environment is removed. All government and local regulations must be observed at all times. Any danger to persons from electrical energy must be excluded by using good installation practices and working according to local regulations.

**Safety Directions for Maintenance, Inspection and Assembly Work**– It is the user's responsibility to make sure that all maintenance, inspection and assembly work is performed exclusively by authorized and qualified experts sufficiently informed through careful perusal of the Operating Instructions. The accident prevention regulations must be observed. All work on the equipment should be done when it is not operational and ideally electrically isolated. The sequence for shutting the equipment down is described in the manual and must be strictly observed. Pumps or pump units handling hazardous liquids must be decontaminated. Immediately upon completion of the work, all safety and protective equipment must be restored and activated.

Before restarting the equipment, all points contained in chapter "Initial Start-up" must be observed.

**Unauthorized Changes and Manufacturing of Spare Parts**– Any conversion or changes of the equipment may only be undertaken after consulting the manufacturer. Original spare parts and accessories authorized by the manufacturer guarantee operational safety. Using non-authorized parts may void any liability on the part of the manufacturer.

**Unauthorized Operation**– The operational safety of the equipment delivered is only guaranteed if the equipment is used in accordance with the directions contained in this manual. Limits stated in the data sheets may not be exceeded under any circumstances.

**Transportation and Intermediate Storage**– Prolonged intermediate storage in an environment of high humidity and fluctuating temperatures must be avoided. Moisture and condensation may damage windings and metal parts. Non-compliance will void any warranty.

## 1.2 Purchase Inspection



**CAUTION:** Properly check the delivery before installation. Never install the drive when you find it damaged or lack a component. Incomplete or defective installation might cause accidents.

### 1.3 Installation

 CAUTION: To ensure effective cooling, the drive must be installed vertically with at least 10 cm space above and below the casing.

 CAUTION: When installed in an indoor location sufficient ventilation must be ensured by a vent or ventilator or similar device. Do not install in a place which is exposed to direct sunlight.

 CAUTION: Do not let the drilling chips fall into the drive fin or fan during installation. This might affect the heat dissipation

### 1.4 Connection

 WARNING: The connection of the drive must be carried out by qualified personnel only. Unqualified handling might lead to shock, burn, or death.

 WARNING: Please double-check that input power has been disconnected before connecting the device, otherwise electrocution or fire can be caused.

 WARNING: The earth terminal must be reliably grounded, otherwise touching the drive shell might lead to a shock.

 WARNING: Selection of PV module type, motor load and drive must be adequate, or the equipment might get damaged.

 WARNING: Grounding of this electrical equipment is mandatory. Never run the pump system when the ground wire is not connected to proper ground. Ignoring this instruction can lead to electrocution.

### 1.5 Operation

 WARNING: The drive should only be connected to power after correct wiring, or the drive might get damaged.

 WARNING: Do not modify the connection while the system is connected to power, or touching any part of it might cause electrocution

 CAUTION: Adjust partial control parameters according to the steps indicated by the manual before the first operation. Do not change the control parameters of the drive by random, or it might damage the equipment.

 CAUTION: The heat sink gets hot during operation. Do not touch it until it has cooled down again, or you might get burned.

 CAUTION: At altitudes of more than 1,000 m above sea level, the drive should be derated for use. Output current should be derated by 10% for every 1,500 m increment of altitude

 CAUTION: Never run the pump when it is not fully submerged in water. When the pump is installed the correct running direction can be determined by measuring the flow rates.

## Chapter 2. Solar pumping system introduction

### 2.1 Solar Pumping System overview

Solar pumping systems can be applied to all forms of daily use, water pumping for drinking water supply for remote villages and farms without connection to the water grid, for agricultural use such as livestock watering, agricultural irrigation, forestry irrigation, pond management, desert control, and industrial use such as waste water treatment etc.

In recent years, with the promotion of the utilization of renewable energy resources, solar pumping systems are more and more used in municipal engineering, city centre squares, parks, tourist sites, resorts and hotels, and fountain systems in residential areas.

The system is composed of a PV panel, a pump and a solar pump drive. Based on the design philosophy that it is more efficient to store water rather than electricity, there is no energy storing device such as storage battery in the system. The system is prepared to be combined with an elevated water storage, e.g. water tower or an uphill tank installation.

The PV generator, an aggregation of PV modules connected in series and in parallel, absorbs solar irradiation and converts it into electrical energy, providing power for the whole system. The pump drive controls and adjusts the system operation and converts the DC produced by the PV module into AC to drive the pump, and adjusts the output frequency in real-time according to the variation of sunlight intensity to realize the maximum power point tracking (MPPT). The pump, driven by 3-phase AC motor, can draw water from deep wells, rivers and lakes and pour it into storage tanks or reservoirs, or be connected directly to the irrigation system, fountain system, etc. According to the actual system demand and installation condition, different types of pumps such as centrifugal pump, axial flow pump, mixed flow pump or deep well pump can be used.

### Solar pump system constitution.

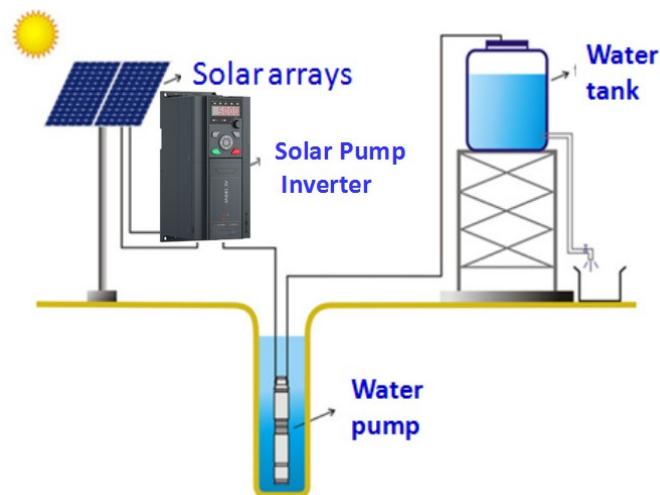

System wiring diagram

### 2.2 Solar pump drive features:

#### Save in energy costs and maximize productivity

Solar pump drives ensure reliable power supply throughout the day with on and off-grid compatibility.

#### Save environment

Harnessing the power of sun provides an environmentally friendly pumping without producing any CO<sub>2</sub> emissions

**Easy install and operation** and little parameters configuration, end user who never used drive before, can install and operate it very well.

**Reduce maintenance costs**

The drives can be equipped with remote monitoring options, reducing maintenance trips to the site.

**Reduce operational risk**

Embedded pump-specific features such as dry run detection, minimum power input protection, maximum current protection, stop frequency running protection.

## Chapter 3. Solar pump drive overview

The solar pump drive is a low voltage AC drive of 0.4 to 400KW power range designed to make use of energy drawn from solar panel or photovoltaic cells (PV). The drive is customized to operate in dual supply mode, so the grid connected supply is used in the absence of energy from PV cells. This drive functions with the latest in technology maximum power point tracking (MPPT) algorithm to derive maximum power from the PV cells at any instant.

The drive is specifically designed to meet the requirements of pump manufacturers and the original equipment manufacturers (OEM).

### 3.1 Product Features

#### Control modes

The solar pump drive operates in local control mode and in remote control mode identical to the ordinary AC drive.

- Local control—interfaces through the operation panel (keypad )
- Remote control—interfaces through external terminals control.

Note: Ensure that the drive is in local control before starting or stopping the inverter using the control panel.

- ✓ Maximum power point tracking (MPPT) with fast response speed and stable operation
- ✓ Dry run (under load ) protection
- ✓ Motor maximum current protection
- ✓ Input power protection
- ✓ Low stop frequency protection
- ✓ The PQ (power/flow) performance curve enables calculating the flow output from the pump
- ✓ Digital control for fully automatic operation, data storage and protective functions
- ✓ Intelligent power module (IPM) for the main circuit
- ✓ LED display operating panel and support remote control
- ✓ Dual mode AC and DC power supply input is available
- ✓ Low water probe sensor, and water level control function
- ✓ Ambient temperature for using: -10 to +50°C.

### 3.2 Solar pump drive operation theory

The solar pump drive uses the maximum power point tracking (MPPT) control program to improve the efficiency of solar energy systems. The output of the photovoltaic (PV) cell is proportional to its area and intensity, while the output voltage is limited by p-n junction from 0.6 to 0.7 V. Therefore when the output voltage is constant, output power is proportional to intensity and surface area. The current and voltage at which the PV cell generates maximum power is known as the maximum power point.

The MPPT controller follows different strategies to derive the maximum power from the PV array. The internal MPPT algorithm is used to derive maximum power from the PV cell at any instant. This is achieved by modifying the operating voltage or current in the PV cell until the maximum power is obtained.

When the output voltage is zero, the PV cells create short circuit current. If the PV cells are not

connected to any load, the output voltage is equal to the open circuit voltage. The maximum power point is obtained at the knee of the I-V curve. See the I-V characteristics shown below.

#### I-V characteristics

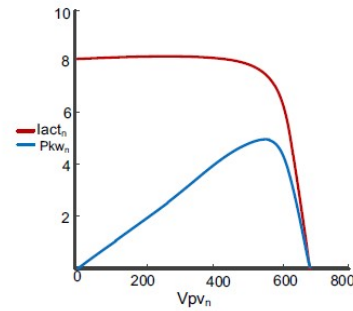

The I-V curve is not constant since intensity and temperature changes during day time. Under constant temperature, current changes linearly with intensity and voltage does not change almost with intensity. Since the voltage variation is small with respect to intensity changes, maximum power varies proportionally with intensity

### 3.3 Solar pump drive compatible with dual supply mode

The solar pump drive operates in dual supply mode either with a three phase input supply from the grid or with DC input supply from PV cells. A four-pole changeover switch enables switching between the two supply modes. At a given time only one supply (PV cell or grid) will be connected to the drive.

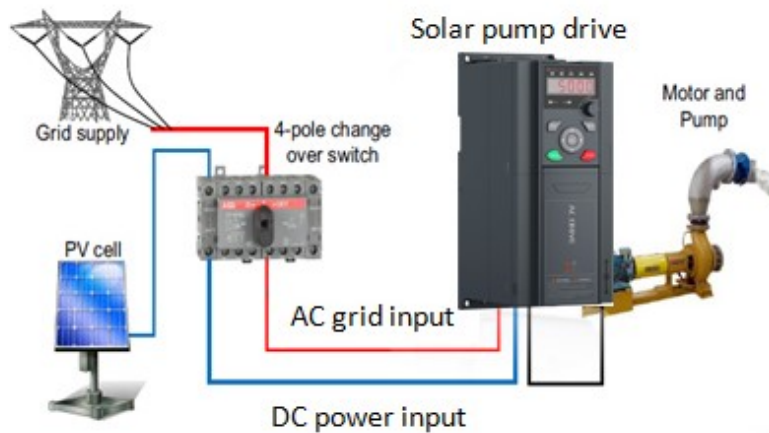

**Note:** Use two poles of the changeover switch in series to ensure that the voltage applied across each pole is half of the full DC voltage.

### 3.4 Solar pump drive model description

The nameplate of solar pump drive

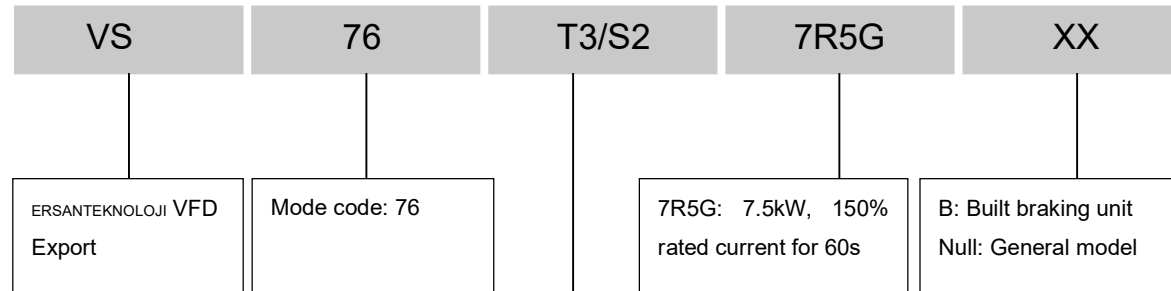

### 3.5 Solar pump drive technical specifications

Recommended MPPT voltage range	T3: 300VDC to 800VDC input, or 3 PH 380VAC to 460VAC input	75Kw to 4kw 450kw
Recommended input voltage	310Vmp DC for 220V AC pumps, 540Vmp DC for 380V AC pumps	
Motor type	Control for permanent magnet synchronous motor and asynchronous motor pumps	
Maximum DC power input	1. 450VDC for 220AC output 2. <b>800VDC or 900VDC</b> for 380V AC output	
Rated output voltage	1 phase, 220V 3 phase, 220V/380V/440V	
Output frequency range	0~400Hz	
MPPT efficiency	99%,	
Ambient temperature range	-10~+50°C	
Solar pump control special performance	MPPT ( maximum power point tracking), CVT (constant voltage tracking), auto/manual operation, dry run protection, low stop frequency protection, minimum power input, motor maximum current protection, flow calculating, energy generated calculating and water tank level detected, etc	
Protection function	Stall protection, phase loss protection, phase short circuit protection , ground to phase short circuit protection , input and output short circuit protection, over-temperature protection, etc	
Protection degree	IP20, Air force cooling	
Running mode	MPPT or CVT	
Altitude	Below 1000m; above 1000m, derated 1% for every additional 100m.	
Standard AC input backup circuit	CE, Design based on vector control drive, more specification please refer to vector control drive operation manual	

### 3.6 Models and specification

SN	Models	Rate current (A)	DC input range (VDC)	Output voltage (VAC)	Applicable for pumps (KW)	Recommended VOC (VDC)	shape and size
1	VS76-S2-0R7G	4.0A	230 to 450	220 to 240	0.75KW	360 to 400	Fig.A

SN	Models	Rate current (A)	DC input range (VDC)	Output voltage (VAC)	Applicable for pumps (KW)	Recommended VOC (VDC)	shape and size
2	VS76-S2-1R5G	7.5A	230 to 450	220 to 240	1.5KW	360 to 400	Fig.A
3	VS76-S2-2R2G	10A	230 to 450	220 to 240	2.2KW	360 to 400	Fig.A
4	VS76-S2-3G	13.5A	230 to 450	220 to 240	3.0KW	360 to 400	Fig.B
5	VS76-S2-4G	16A	230 to 450	220 to 240	4.0KW	360 to 400	Fig.B
6	VS76-T3-0R7GB	2.5A	350 to 800	380 to 440	0.75KW	650 to700	Fig.A
7	VS76-T3-1R5GB	3.7A	350 to 800	380 to 440	1.5KW	650 to700	Fig.A
8	VS76-T3-2R2GB	5.0A	350 to 800	380 to 440	2.2KW	650 to700	Fig.A
9	VS76-T3-4GB	10A	350 to 800	380 to 440	4.0KW	650 to700	Fig.A
10	VS76-T3-5R5GB	13A	350 to 800	380 to 440	5.5KW	650 to700	Fig.B
11	VS76-T3-7R5GB	17A	350 to 800	380 to440	7.5KW	650 to700	Fig.B
12	VS76-T3-11GB	25A	350 to 800	380 to 440	11KW	650 to700	Fig.C
13	VS76-T3-15GB	33A	350 to 800	380 to 440	15KW	650 to700	Fig.C
14	VS76-T3-18GB	38A	350 to 800	380 to 440	18.5KW	650 to700	Fig.C
15	VS76-T3-22GB	45A	350 to 800	380 to 440	22KW	650 to700	Fig.C
16	VS76-T3-30G	60A	350 to 800	380 to 440	30KW	650 to700	Fig.C
17	VS76-T3-37G	75A	350 to 800	380 to 440	37KW	650 to700	Fig.C
18	VS76-T3-45G	91A	350 to 800	380 to 440	45KW	650 to700	Fig.C
19	VS76-T3-55G	110A	350 to 800	380 to 440	55KW	650 to700	Fig.C
20	VS76-T3-75G	150A	350 to 800	380 to 440	75KW	650 to700	Fig.C
21	VS76-T3-90G	180A	350 to 800	380 to 440	90KW	650 to700	Fig.C
22	VS76-T3-110G	210A	350 to 800	380 to 440	110KW	650 to700	Fig.C
23	VS76-T3-132G	250A	350 to 800	380 to 440	132KW	650 to700	Fig.C
24	VS76-T3-160G	300A	350 to 800	380 to 440	160KW	650 to700	Fig.C
25	VS76-T3-185G	340A	350 to 800	380 to 440	185KW	650 to700	Fig.C
26	VS76-T3-200G	380A	350 to 800	380 to 440	200KW	650 to700	Fig.C
27	VS76-T3-220G	415A	350 to 800	380 to 440	220KW	650 to700	Fig.C
28	VS76-T3-250G	470A	350 to 800	380 to 440	250KW	650 to700	Fig.C
29	VS76-T3-280G	520A	350 to 800	380 to 440	280KW	650 to700	Fig.C
30	VS76-T3-315G	600A	350 to 800	380 to 440	315KW	650 to700	Fig.C
31	VS76-T3-355G	680A	350 to 800	380 to 440	355KW	650 to700	Fig.C
32	VS76-T3-400G	750A	350 to 800	380 to 440	400KW	650 to700	Fig.C

### 3.7 Inverter shape and size comparison table (attached table)

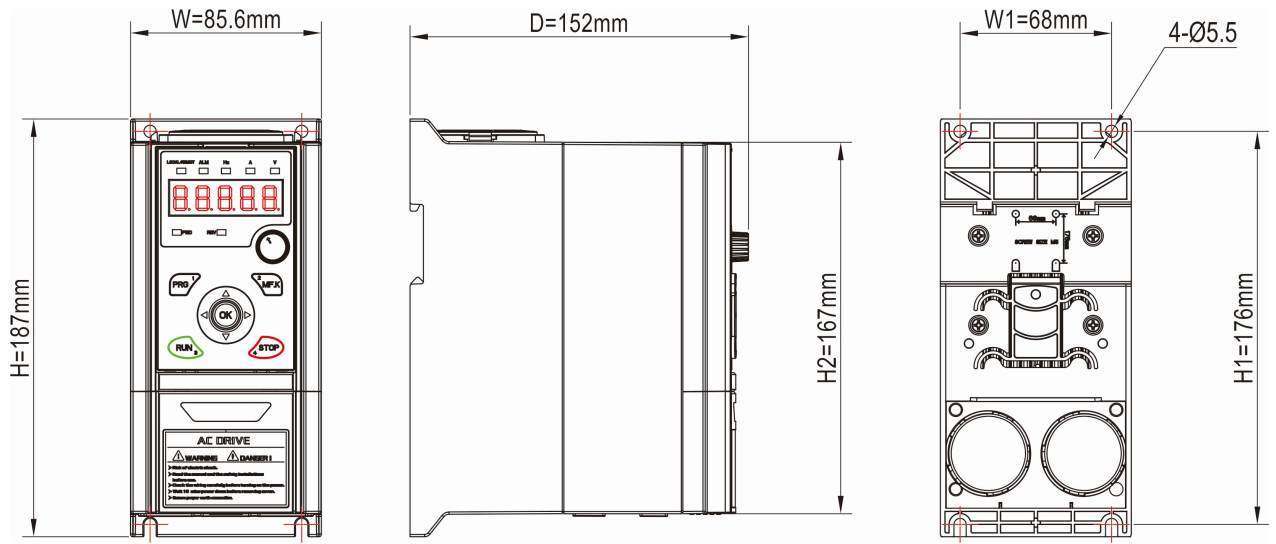

Fig. A

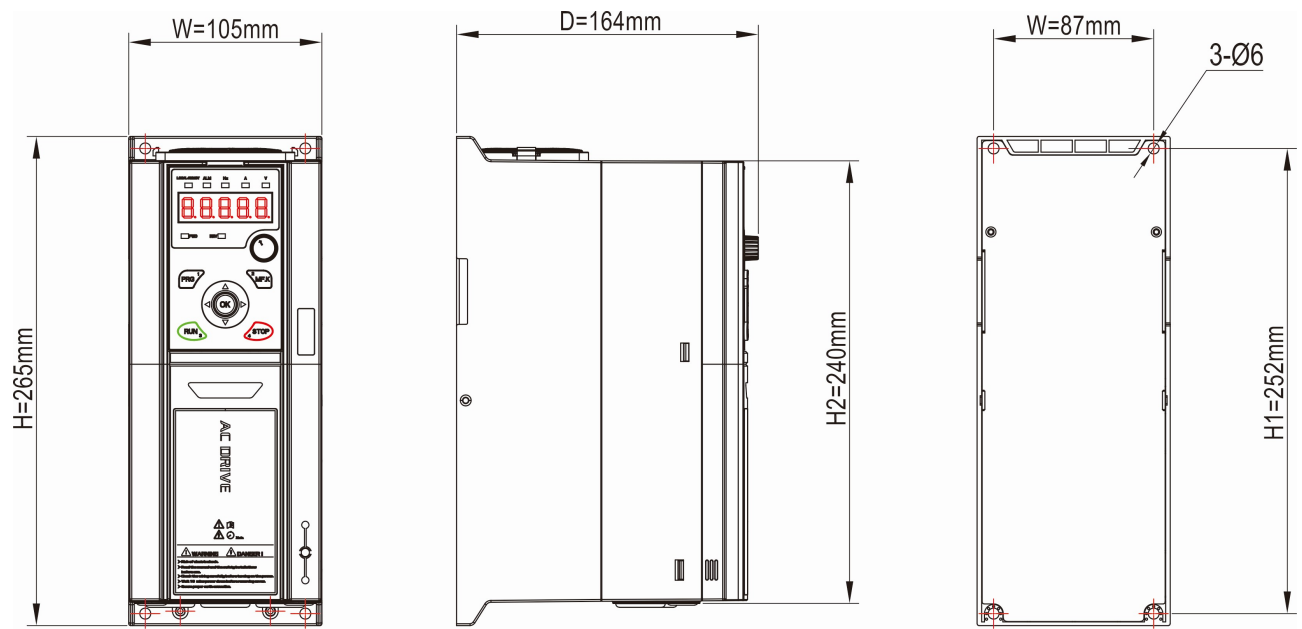

Fig. B

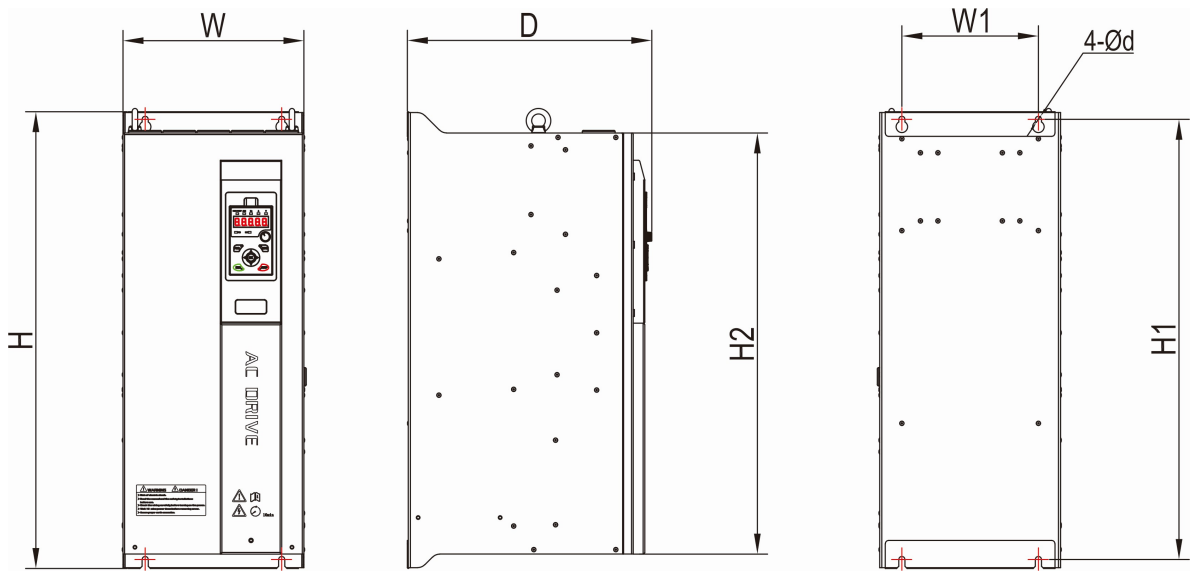
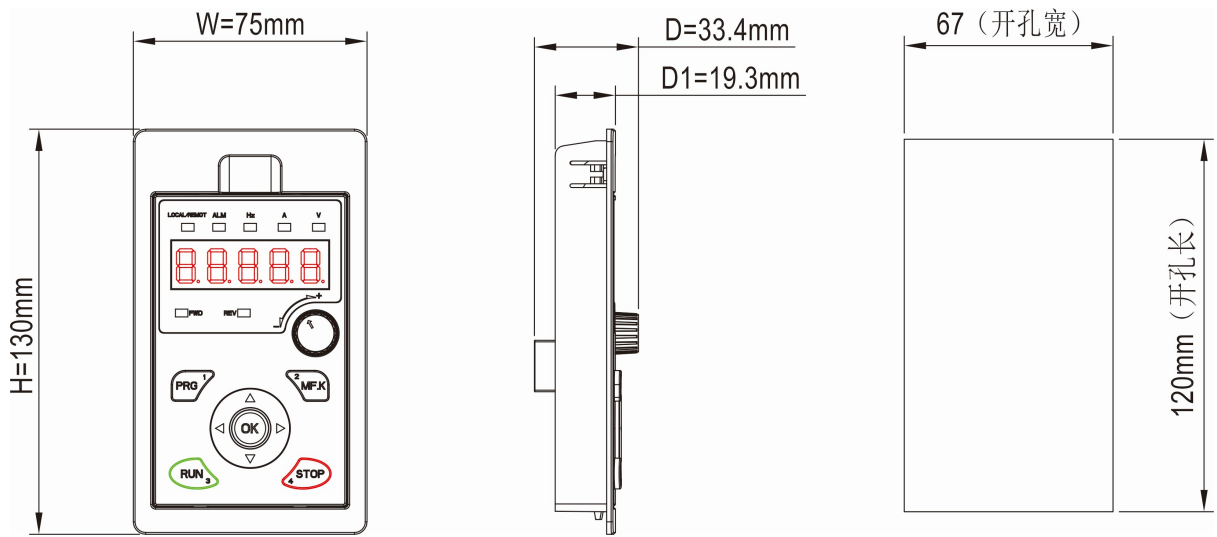

Fig.C



VS76-KB005 Keyboard and Tray Dimensions Hole Diagram

VFD specifications and models	Dimension ( mm )			Mounting holes size ( mm )		Mounting holes (mm)	Fig	Remark
	W	H	D	W1	H1	∅ d	Fig	Wiring
<b>1 PHASE S2 220V</b>								
VS76-S2-0R7G	86	187	152	68	176	5.5	A	down in down out wall mounted
VS76-S2-1R5G								
VS76-S2-2R2G								
VS76-S2-3G	105	265	164	87	252	6	B	down in down out wall mounted
VS76-S2-4G								
<b>3 PHASE T3 380V</b>								
VS76-T3-0R7GB	86	187	152	68	176	5.5	A	down in down out wall mounted
VS76-T3-1R5GB								
VS76-T3-2R2GB								
VS76-T3-4GB								
VS76-T3-5R5GB	105	265	164	87	252	6	B	down in down out wall mounted
VS76-T3-7R5GB								
VS76-T3-11GB	150	333	216	100	314	5.5	C	down in down out wall mounted
VS76-T3-15GB								
VS76-T3-18GB	180	383	228	120	363	6.5	C	down in down out wall mounted
VS76-T3-22GB								
VS76-T3-30G	175	435	265	130	420	6.5	C	down in down out book type
VS76-T3-37G								
VS76-T3-45G	265	670	358	200	645	9	C	up in down out book type
VS76-T3-55G								
VS76-T3-75G								
VS76-T3-90G	305	845	358	200	820	11	C	up in down out book type
VS76-T3-110G								
VS76-T3-132G								
VS76-T3-160G	420	880	400	300	845	11	C	down in down out book type
VS76-T3-185G								
VS76-T3-200G								
VS76-T3-220G								
VS76-T3-250G	480	1000	420	340	966	11	C	down in down out book type
VS76-T3-280G								
VS76-T3-315G	680	1010	437	520	976	11	C	down in down out book type
VS76-T3-355G								
VS76-T3-400G								

## Chapter 4. Operation control panel description

### 4.1 Press function key description



Key symbol	Name	Function description
PRG	Menu key	Enter menu or exit
OK	Confirm key	Enter to menu step by step and confirm the setting value
▲	UP increase key	Data and function code increase
▼	DW reduce key	Data and function code reduce
◀ ▶	Shift	In the monitor status, press this key can select display monitoring parameter in circulation.
RUN	Running key	Use to start drive in keypad control mode
MF.K	Multiple function key	Programmed by F4-31 setting. Default is reverse running
STOP	Stop and reset	In running status, this key can use to stop operation (F0-02). Reset malfunction in alarm mode.

### 4.2 Indicator description

Symbol	Indicator description
Hz	Unit of frequency (Hz)
A	Unit of current (Amp)
V	Unit of voltage (V)
FWD	Forward run indicator
REV	Reverse run indicator FWD, REV both flash in stand for DC braking
ALM	Fault indicator (alarm for over current, over voltage but that don't reach the level of fault limit)

### **4.3 Digital display area**

5 digit LED display, it can use to display frequency reference, output frequency and kinds of monitoring data and fault alarm code.

### **4.4 Function code operation**

There are 3 level menu in respectively.

1. Function code parameters (First level menu)
2. Function code name (The second level menu)
3. Setting value of function code ( the third level menu )

Note: If in the third level menu, you can press PRG or OK key to return second menu.

The difference is that press OK key will set parameter in controller board and then return to the second menu, press PRG key an return second menu directly without parameters storing.

### **4.5 Monitor parameters inquiry.**

There two ways to inquiry monitoring parameters.

1. Press “◀”to inquiry 6 solar pump control common parameters ( It is set by F4-26, F4-27, F4-28 )( Output frequency, output current, output voltage, DC voltage, DC current and input power )
2. User also can go to d parameters to inquiry relative parameters.

### **4.6 Fault reset**

Solar pump drive will display relative fault information if there are any alarm occurs.

User can reset it by “STOP” or external terminals (F5 group setting). Once reset, drive place on standby status.

If drive place in fault status and without any reset, it is located in protection status and can't working.

#### **Note:**

**Solar pump drive perform itself initialize when power on.**

**The system of drive will initialize by itself when power on. The LED of keypad display VS76drv when DC bus of dive from low to high.**

**When DC bus reach start point, LED will display the frequency reference and flash all the time, means drive place on standby status.**

# Chapter 5. Solar pump drive installation

## 5.1 About this chapter

This chapter includes the basic information about the mechanical and electrical installation of solar pump drive and also provides steps to quickly operate the inverter.

For general instructions on installation and maintenance, see *User's manual please*.

### Safety instructions

**WARNING! All electrical installation and maintenance work on the drive must be carried out by qualified electricians only. Follow the safety instructions listed below.**

- **Never work on the inverter, the braking chopper circuit, the motor cable or the motor when input power is applied to the inverter.**
- **After disconnecting the input power, always wait for 5 minutes to let the intermediate circuit capacitors discharge. Always ensure by measuring that no voltage is actually present.**
- **A rotating permanent magnet motor generates a dangerous voltage. Always ensure to lock the motor shaft mechanically before connecting a permanent magnet motor to the inverter, and before doing any work on a drive system connected to a permanent magnet motor.**

## 5.2 Mechanical installation

In back mounting, fasten the drive to the wall with screws using four mounting holes.

### Note: Installation Environment Requirements

1. Ambient temperature, the surrounding environment temperature take great effect for service life span of solar pump drive, don't allow surrounding temperature over than allowable temperature above (-10°C to +50°C)
2. Heat dissipation, install the solar drive on the surface of an incombustible object, and ensure that there is sufficient space around for heat dissipation. Install the solar pump drive vertically on the support using screws.
3. Vibration, it should be less than 0.6G, far away from the punching machine or the like.
4. Free from direct sunlight, high humidity and condensation
5. Free from corrosive, explosive and combustible gas
6. Free from oil dirt, dust and metal powder

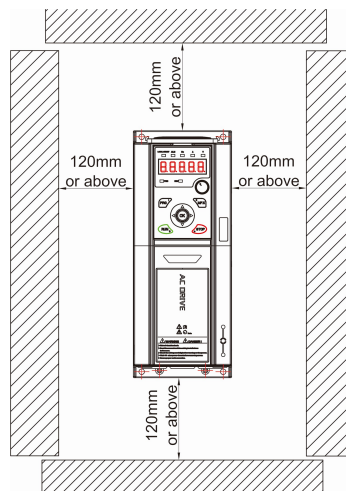

### 5.3. Installation and wiring

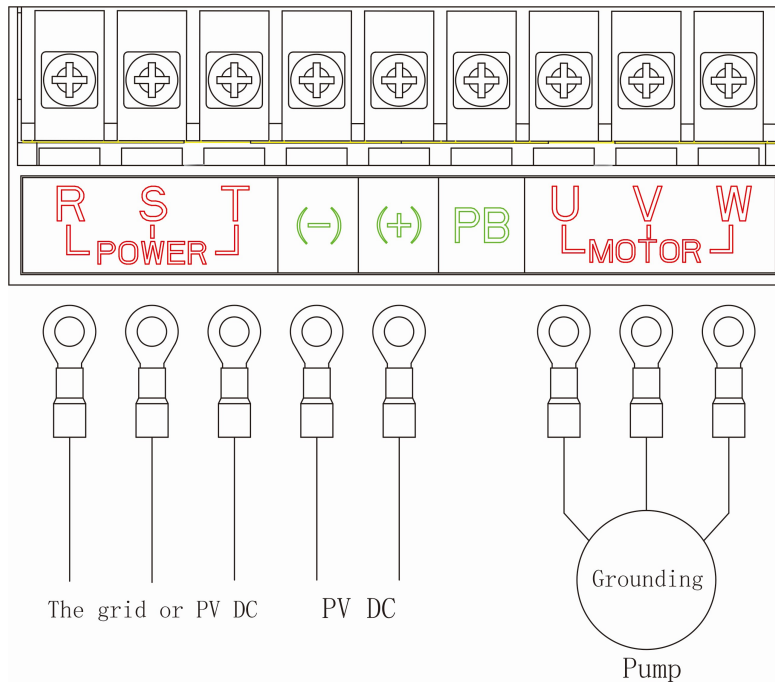

**Note:**

- Do not use an asymmetrically constructed motor cable.
- Route the motor cable, input power cable and control cables separately.
- Make sure that the maximum cable lengths are not exceeded. For detailed information, see the user's manual.

### 5.4 Main circuit terminals description

Terminals symbol	Function description
+ and P+ mean the same thing - and P- mean the same thing	Positive and negative terminals of DC bus voltage
R, S, T	AC input connecting or DC input connect
U, V, W	Connect to motor
PE or E	Grounding terminals

### 5.5 Connection procedure

1. Strip the input power cable. Ground the bare shield of the cable (if any) 360 degrees under the grounding clamp. Fasten the grounding conductor (E) of the input power cable under the screw of the grounding clamp. Connect the phase conductors to the R,T terminals from PV solar panel.
2. Strip the motor cable. Ground the bare shield of the cable 360 degrees under the grounding clamp. Twist the shield to form as short a pigtail as possible and fasten it under the screw of the grounding clamp. Connect the phase conductors to the U, V and W terminals.
3. Secure the cables outside the drive mechanically.

# Chapter 6. Solar pump drive commissioning guide

## 6.1 Wiring and commission steps

### 6.1.1 Commissioning steps

1. Wiring according to the diagram and check the wiring if correct or not
2. Check the solar power input DC voltage if matching rated of drive. (T3 series need Voc 650DCV, 2T series need Voc 370V)
3. Switchover to solar DC power input if DC voltage is correct.
4. Parameters setting and motor trial starting.

(a) Solar pump control parameters is A5, A6 and A7 group. Only two parameters need to be confirmed by first time using.

A5-00=2 for MPPT function in default. If A5-00 is 0, it only allow for AC grid input, not solar power input.

A5-01=0 means for operating by manual with keypad in default. If needs run automatically, please set A5-01 for 1.

(b) Set motor group parameters F2-00 to F2-05 according motor nameplate for asynchronous induction motor.

(c) Perform motor trial running with press RUN key to starts pump and observe the running frequency and the water yield. **If the sunlight radiation is good, and frequency goes up, but water flow is very small. Might the direction of pumps running is not correct, please to change motor wiring phase.**

(d) Set the low stop frequency protection, low voltage sleep protection, dry run (under-load) protection, motor maximum protection and water tank level function if need according user request.

(e) If the output frequency is a little fluctuation, user can set A5-05 (Frequency adjust gain) to smaller, and set A5-07 to smaller value. Otherwise if A.Luo alarm occurs frequently, please set A5-05 bigger, and increase the A5-07 value.

(f) If solar pump drive runs well, and system working is stable, the commissioning is finished. Set A5-01 to 1 for automatically running control. The solar pump system can work with MPPT function according sunlight radiation automatically.

**Note: If user need start pumps with AC grid input, please connect AC power supply to R, S,T. and set A5-00 for 0, or switch on X? (X2 and COM short circuit connection) to disable solar pump control function.**

### Excluded functions

The following features of this series solar pump drive firmware are not supported in the solar pump inverter.

- Frequency input
- Sequential programming
- Jogging
- Constant speed
- speed slip compensation
- Mechanical brake

## **Solar pump drive wiring with dual mode AC grid and solar DC power input.**

Note.

Note: The required input solar panel voltage is 1.2 times of solar drive DC bus voltage.

For example: In T3 series, recommend  $540V \times 1.2 = 648V$ ;

in 2T series, recommend  $311 \times 1.2 = 373V$ .

The required power of solar arrays is 1.3 times of rated power of drives, shouldn't less than 1.2 times of rated power of inverter.

For example, 7K5G, the required power is  $7500 \times 1.3 = 9750w$ .

## Chapter 7. Simple parameter list

### Table Symbol Description:

☆ - Indicates that the parameter can be changed in the process of stopping and running.

✖ - Indicates that the parameter can be changed in stop mode, can not be changed during running;

\* - Indicates that the initial parameters related to the drives model

Below list all parameters for AC drives, not only for solar pump control but also for motor speed and torque control. Blue and bold words stands for parameters which may relative to solar pump control function.

### 7.1 F0. parameters for basic running control

Code	Name	Description	Unit	Default setting	Property
F0-01	Control mode	0: VF control (for ASM) 3: High performance open loop vector control 2(for ASM and PMSM)	1	0	✖
F0-02	Running command channel selection	0: Operation panel (keypad) 1: External terminals 2: RS485terminals	1	0	☆
F0-03	Main frequency reference source A	0: Potentiometer of keypad 1: UP, DOWN of keypad. 2: AI1 (0-10V) 3: AI2 ( 0-10V/0-20mA) 5: PID close loop reference 6: Multi-segment speed control 7: Simple PLC 8: UP/DW of terminals 9: Communication 11: High speed pulse trains	1	0	☆
F0-04	Auxiliary frequency reference source B	0: Potentiometer of keypad 1: AI1 ( 0- 10V ) 2: AI2 ( 0-10V ) 3: F0-07 4: High speed pulse trains reference 5: Multi-segment speed	1	1	☆
F0-05	The reference source selection of auxiliary frequency source B	0: Upper limit frequency 1: Main frequency source A	1	0	☆
F0-06	The operation of frequency source A and B combination setting	0: Main frequency source A 1: Auxiliary frequency source B 2: A+B 3: MAX (A, B) 4: MIN (A, B) 5: A-B	1	0	☆
F0-07	UP and Down key of keypad setting	0~Upper limit frequency	0.01	50.00	☆

Code	Name	Description	Unit	Default setting	Property
F0-08	Upper limit frequency	5.00~650.00 Hz	0.01	50.00	×
F0-09	Lower limit frequency	0.00Hz ~ F0-08	0.01	0.50	×
F0-10	Running mode under low limit frequency	0: Running with lower limit frequency 1: Stop 2: Sleep mode in stand by	1	0	×
F0-11	Wake up time in sleep mode	0.0~6000.0 S	0.1	0.0	×
F0-12	Acceleration mode 1	0.1~6000.0 s	0.1	*	☆
F0-13	Deceleration mode 1	0.1~6000.0s	0.1	*	☆
F0-14	Carrier frequency	1 ~ 10.0KHz	0.1	*	☆
F0-15	Ac drive running direction	0: Runs as forward direction 1: Runs as reverse direction 2: Reverse direction is forbidden	1	0	☆
F0-16	Parameters display in standby mode	0~3939 (corresponding with d parameters)	1	0503	☆
F0-17	Factory restore to factory setting	0: No operation 11: Parameters initialization 22: Clear fault record <b>33: Parameters initialization for solar pump control</b>	1	0	×
F0-18	Parameters modify protection	0: No protection 1: Disable modify	1	0	×
F0-19	STOP operation range	0: Enable on keypad operation mode 1: Enable on all command mode	1	0	×

## 7.2 F1 parameters for start and stop parameters

Code	Name	Description	Unit	Default setting	Property
F1-00	Start up mode	0: Start up with starting frequency 1: Start up after DC braking 2: Start up with speed tracking	1	0	×
F1-01	Starting frequency	0.00~10.00Hz	0.01	0.50	×
F1-02	Starting frequency holding time	0.0~20.0s	0.1	0.0	×
F1-03	DC braking current when starting	0~150.0%	1	50.0	×
F1-04	DC braking time when starting	0.0~30.0s	0.1	0.0	×
F1-05	Stop mode	0: Deceleration to stop 1: Free stop	1	1	☆
F1-06	Dc braking start frequency when stop	0.00~50.00Hz	0.01	3.00	×
F1-07	Dc braking current when stop	0~150.0%	1	50.0	×

Code	Name	Description	Unit	Default setting	Property
F1-08	DC braking holding time when stop	0.0~60.0s	0.1	0.0	×
F1-09	Speed tacking arithmetic Selection	0: Minimum current arithmetic 1: Voltage/frequency arithmetic.	1	0	×
F1-10	Waiting time of speed tacking	0.0 ~ 10.0s	0.1	1.0	×
F1-11	Speed tacking search time	3.0 ~ 100.0s	0.1	6.0	×
F1-12	Current setting of speed tacking finished	1.00 ~ 50.00%	0.01	15.00	×
F1-13	Starting voltage when braking	105.0~140.0%	0.1	123.0	☆
F1-14	Final voltage when braking	105.0~150.0%	0.1	128.0	☆
F1-15	Terminals running command detect when power on	0: Running command is disable when power on 1: Running command enable when power on	1	0	×
F1-16	Stop speed	0.00~100.00%	0.01	1.00	☆
F1-17	Stop speed detect mode	0: Detect as speed reference 1: Detect as actual speed ( for vector control )	1	1	☆

### 7.3 F2 motor parameters group

Code	Name	Description	Unit	Default setting	Property
F2-00	Motor type	0: Asynchronous motor 1: Permanent magnet synchronous motor	1	0	×
F2-01	Motor rated voltage	1~700V	1	*	×
F2-02	Motor rated frequency	5.00~600.00Hz	0.01	50.00	×
F2-03	Motor rated current	0.1~3000.0A	0.1	*	×
F2-04	Rated slip frequency	0.00~5.00Hz	0.01	*	×
F2-05	Poles pair	1~50	1	2	×
F2-06	No load current	10.0~ 80.0%	0.1	*	×
F2-07	Stator resistor	0.00~50.00%	0.01	*	×
F2-08	Rotor resistance	0.00~50.00%	0.01	*	×
F2-09	Leakage inductance	0.00~50.00%	0.01	*	×
F2-10	Motor parameter auto-tuning	0: No operation 1: static auto tuning 2: Completely auto tuning	1	0	×
F2-11	Rated frequency of PMSM	5.00~600.00Hz	0.01	50.00	×
F2-12	Rated voltage of PMSM	1~700V	1	*	×

Code	Name	Description	Unit	Default setting	Property
F2-13	Rated current of PMSM	0.1~3000.0A	0.1	*	×
F2-14	Rated back EMF of PMSM	1~700V	1	*	×
F2-15	Stator resistance of PMSM	0.00~50.00%	0.01	*	×
F2-16	d-axis inductance of PMSM	0.00~300.00%	0.01	15.00	×
F2-17	q-axis inductance of PMSM	0.00~300.00%	0.01	15.00	×

**PMSM stands for Permanent magnet synchronous motor**

#### 7.4 F3 group parameters for Vector control and V/f control

Code	Name	Description	Unit	Default setting	Property
F3-00	Low speed ASR proportional coefficient	0.01 ~ 30.00	0.01	0.60	☆
F3-01	Low speed ASR integral coefficient	0.01 ~ 10.00	0.01	1.00	☆
F3-02	ASR switching frequency 1	1.00~7.50Hz	0.01	5.00	☆
F3-03	High speed ASR proportional coefficient	0.01 ~ 30.00	0.01	0.60	☆
F3-04	High speed ASR integral coefficient	0.01 ~ 10.00	0.01	1.00	☆
F3-05	ASR switching frequency 2	8.00~50.00Hz	0.01	10.00	☆
F3-06	Current loop proportional coefficient	1~1000.0	1	100.0	×
F3-07	Current loop integral coefficient	1~1000.0	1	100.0	×
F3-08	Slip compensation coefficient	50~200%	1	100	×
F3-10	Torque limit	0~200%	1	150	×
F3-11	Cross compensation coefficient	0.00 ~ 0.50	0.01	0.20	×
F3-12	Closed-loop voltage proportional coefficient	0~ 1.00	0.01	0.20	×
F3-13	Voltage closed-loop integral coefficient	0~ 1.00	0.01	0.20	×
F3-14	Magnetic field control proportional coefficient	10~1000	1	50	×
F3-15	Magnetic field control integral coefficient	1~500	1	50	×
F3-16	Current reference filter time constant	1~10	1	3	×
F3-17	Whether torque control	0: Torque control disable 1: Torque control enable	1	0	☆

Code	Name	Description	Unit	Default setting	Property
F3-18	Torque reference	0: Torque reference set by F3-19 1: AI1 2: AI2 3: Multi-segment speed 4: RS485 5: HDI	1	0	☆
F3-19	Torque reference by keypad setting	0.0~200.0%	0.1	50.0	☆
F3-20	Torque reference direction	0: Forward direction 1: Reverse direction	1	0	☆
F3-21	Upper limit frequency reference source set selection	0: Upper limit frequency 1: AI1 2: AI2 3: Multi-segment speed 4: RS485 5: HDI 6: Potentiometer of keypad	1	0	☆
F3-22	V/F curve selection	0: Standard V/F curve, V/F=constant 1: Torque-down V/F curve (power of 2) 2: User defined V/f curve 3: Torque-down V/F curve (power of 1.3) 4: Torque-down V/F curve (power of 1.7)	1	3	×
F3-23	Custom curve F1	0.0 ~ 100.0%	0.1	0.0	×
F3-24	Custom curve V1	0.0 ~ 100.0%	0.1	0.0	×
F3-25	Custom curve F2	0.0 ~ 100.0%	0.1	0.0	×
F3-26	Custom curve V2	0.0 ~ 100.0%	0.1	0.0	×
F3-27	Custom curve F3	0.0 ~ 100.0%	0.1	0.0	×
F3-28	Custom curve V3	0.0 ~ 100.0%	0.1	0.0	×
F3-29	Torque boost	0.0 ~ 20.0%	0.1	*	×
F3-30	Low frequency oscillation suppression strength	0~1000	1	100	×
F3-31	High frequency oscillation suppression strength	0~1000	1	0	×
F3-32	High and low frequency turning point	5.00~50.00 Hz	0.01	20.00	×
F3-33	V / F control slip compensation coefficient	0~200%	1	0	×

## 7.5 F4 group parameters for auxiliary running control

Code	Name	Description	Unit	Default setting	Property
F4-00	Forward /reverse dead time	0.0~5.0s	0.1	0.1	☆
F4-01	Skip frequency 1	0.00 ~Upper limit frequency	0.01	0.00	☆
F4-02	Skip frequency 1 range	0.00 ~5.00Hz	0.01	0.00	☆
F4-03	Skip frequency 2	0.00 ~ Upper limit frequency	0.01	0.00	☆
F4-04	Skip frequency 2 range	0.00 ~5.00Hz	0.01	0.00	☆
F4-05	Skip frequency 3	0.00 ~ Upper limit frequency	0.01	0.00	☆
F4-06	Skip frequency 3 range	0.00 ~5.00Hz	0.01	0.00	☆
F4-07	Jog frequency	0.00~ Upper limit frequency	0.01	5.00	☆
F4-08	Jog acceleration time	0.1~6000.0s	0.1	10.0	☆
F4-09	Jog deceleration time	0.1~6000.0s	0.1	10.0	☆
F4-10	Acceleration time 2	0.1~ 6000.0S	0.1	*	☆
F4-11	Deceleration time 2	0.1~ 6000.0S	0.1	*	☆
F4-12	Acceleration time 3	0.1~ 6000.0S	0.1	*	☆
F4-13	Deceleration time 3	0.1~ 6000.0S	0.1	*	☆
F4-14	Acceleration time 4	0.1~ 6000.0S	0.1	*	☆
F4-15	Deceleration time 4	0.1~ 6000.0S	0.1	*	☆
F4-16	Acceleration /deceleration mode	0: Linear, 1: S curve	1	0	×
F4-17	Terminal UP/DW rate	0.01~100.00Hz/s	0.01	1.00	☆
F4-18	FDT 1 (frequency detect level) setting	0.00~upper limit frequency	0.01	50.00	☆
F4-19	FDT 1 lag detection value	0.0~100.0%	0.1	5.0	☆
F4-20	FDT 2 (frequency detect level) setting	0.00~upper limit frequency	0.01	50.00	☆
F4-21	FDT 2 lag detection value	0.0~100.0%	0.1	5.0	☆
F4-22	Frequency arrival detection range	0 0.00~20.00Hz	0.01	1.00	☆
F4-23	PWM modulation	Unit 's digit: if over modulation 0: Not modulation 1: Modulation Ten's digit: Modulation mode 0: Three phase modulation at low speed, two phase modulation at high speed 1: Always three phase modulation Hundred's digit: Low speed deal with 0: When the low speed	1	0	×

Code	Name	Description	Unit	Default setting	Property
		carrier frequency large than 3Khz, runs with within 3Khz. 1: Carrier frequency runs with previous setting			
F4-24	AVR (auto voltage regulation)	0: no operation 1: Enable 2: Disable in deceleration	1	1	×
F4-25	Drop control	0.0~10.00Hz	0.01	0.0	×
F4-26	Operation monitoring items selection	0~3939: Low two bit and high two bit, each stands for one d parameters. 3 parameters can determine 6 monitor parameters, press Shift key to circulation display in running.	1	0100	☆
F4-27	Operation monitoring items selection 2		1	0302	☆
F4-28	Operation monitoring items selection 3		1	3205	☆
F4-29	Speed display coefficient	0.1~999.9%	0.1	100.0	☆
F4-30	Linear speed display coefficient	0.01~99.99	0.01	1.00	☆
F4-31	Multifunction key MF.K set	0: REV 1: Jog forward 2: Jog Reverse 3: Running command switchover	1	0	×

## 7.6 F5 group parameters for external terminals input and output

Code	Name	Description	Unit	Default setting	Property
F5-00	AI1 minimum input	0.00~10.00V	0.01	0.00	☆
F5-01	AI1 minimum input corresponding value	-100.00~100.0%	0.1	0.0	☆
F5-02	AI1 maximum input	0.00~10.00V	0.01	10.00	☆
F5-03	AI1 maximum input corresponding value	-100.00~100.0%	0.1	100.0	☆
F5-04	AI1 filter time constant value	0.01~50.00s	0.01	0.10	☆
F5-05	AI2 minimum input	0.00~10.00V	0.01	0.00	☆
F5-06	AI2 minimum input corresponding value	-100.00~100.0%	0.1	0.0	☆
F5-07	AI2 maximum input	0.00~10.00V	0.01	10.00	☆
F5-08	AI2 maximum input corresponding value	-100.00~100.0%	0.1	100.0	☆
F5-09	AI2 filter time constant value	0.01~50.00s	0.01	0.10	☆

Code	Name	Description	Unit	Default setting	Property
F5-10	PLUSE minimum input	0.00~50.00KHz	0.01	0.10	☆
F5-11	PLUSE minimum input corresponding value	-100.00~100.0%	0.1	0.0	☆
F5-12	PLUSE maximum value	0.00~50.00KHz	0.01	50.00	☆
F5-13	PLUSE Maximum value corresponding value	-100.00~100.0%	0.1	100.0	☆
F5-14	PULSE filter time constant value	0.01~50.00s	0.01	0.10	☆
F5-15	External terminal command control mode	0: Two lines control mode 1 1: Two lines control mode 2 2: Three lines control mode 1 3: Threes lines control mode 2	1	1	×
F5-16	X1terminals function selection (0~50)	0: No function 1: FWD Forward command 2: REV Reverse command 3: External fault input (normally open) 4: DC braking 5: Emergency stop input ( solar pump pause )		1	×
F5-17	X2 terminals function selection (0~50)	6: Fault reset input 7: Multi-speed input 1 8: Multi-speed input 2 9: Multi-speed input 3 10: Multi-speed input 4 11: three-line control 12: Terminal UP 13: Terminal DOWN		2	×
F5-18	X3 terminals function selection (0~50)	14: Terminal reset 15: Acceleration and deceleration selection terminal 1 16: Acceleration and deceleration selection terminal 2 17: PLC Pause running		7	×
F5-19	X4 terminals function selection (0~50)	18: PLC state reset (modes 1, 2) 19: Forward jog 20: reverse jog 21: Traverse suspend operation 22: Traverse reset 23: PID suspend operation		8	×

Code	Name	Description	Unit	Default setting	Property
F5-20	X5 terminals function selection (0~50)	24: Interior timer enable 25: The internal timer is cleared 26: Counter trigger input 27: Counter Reset (reset to 0) 28: Frequency reference given A and B switchover 29: Frequency reference given A and A + B switchover		1	×
F5-21	X6 terminals function selection (0~50)	30: Frequency reference given B and A + B switchover 31: deceleration to stop 32: Torque control prohibition 33: Length counter input 34: The length of the counter is cleared 35: Command given source is forcibly set by keypad 36: Command given source is forcibly set by terminal 37: Command given source is forcibly set by the communication. 38: PID parameters 39: External fault normally closed input 40: Pulse input (only valid for X6) 42: Solar control prohibition 43: Normally Open point alarm 44: Normally closed point alarm		10	×
F5-27	Y transistor output selection	0: No function 1: Run state 2: Fault output 3: Frequency arrival 4: detection frequency FDT1 arrival	1	1	☆
F5-28	Relay 1 output selection	5: detection frequency FDT2 arrival 6: Zero speed running 7: Lower limit frequency arrival	1	1	☆

Code	Name	Description	Unit	Default setting	Property
F5-29	Relay 2 output selection	8: Upper limit frequency arrival 9: Counter reaches the specified value (greater than the specified value, output ON) 10: Counter reach final value (equal to the final value, output a ON clock cycle counter signal ) 11: Internal timer reaches (Output a ON timer unit signal) 12: Running time is reached (greater than the set time Output ON) 13: PLC a segment operation is completed ( Output a 0.5s ON signal) 14: PLC run cycle is complete ( Output a 0.5s ON signal) 15: Over-torque warning 16: Drive standby 17: Length arrive 18: Place in sleep mode 19: AI1 input over limit 20: Module temperature reaches	1	1	☆
F5-34	AO1 output selection	0: Frequency reference 1: Run Frequency 2: Output current 3: DC bus voltage 4: Output voltage 5: output power (100% corresponds to 200% of rated power) 6: Torque current 7: AI1 8: AI2 9: Reserved 10: High-speed pulse input 11: RS485 set 12: Length 13: count value 14 to 20 Reserved	1	0	☆

Code	Name	Description	Unit	Default setting	Property
F5-35	AO1 analog output corresponding to 0%	0.0~100.0%, output 0~10V, 100.00% corresponding to 10V, output 0~20mA, 100.00% corresponding to 20mA.	0.1	0.0	☆
F5-36	AO1 analog output corresponding to 100.00%	0.0~100.0%	0.1	100.0	☆
F5-39	AO2 output type selection	0: Analog 1: HDO pulse trains output	1	0	☆
F5-40	HDO pulse train upper limit	0.10~50.00KHz	0.01	50.00	☆
F5-41	AO2 output selection	As same as AO1 selection	1	1	☆
F5-42	AO2 analog output corresponding to 0%	0.0~100.0%, when output 0~10V, 100.0% corresponding to 10V; when output is high speed pulse train , 100.0% correspond to 50.00KHz	0.1	0.0	☆
F5-43	AO2 analog output corresponding to 100.00%	0.0~100.0%	0.1	100.0	☆

### 7.7 F6 group parameters for PID control

Code	Name	Description	Unit	Default setting	Property
F6-00	Select PID reference command source	0: Potentiometer of keypad 2: F6.01 reference 3: AI1 4: AI2 5: RS485 6: PLUSE trains 7: multi-speed	1	0	☆
F6-01	PID reference	0~100.0%	0.1	50.0	☆
F6-02	PID feedback channel selection	0: AI1 1: AI2 2: HDI 3: RS485	1	0	☆
F6-03	Regulation characteristics	0: Positive 1: Negative	1	0	☆
F6-04	Proportional gain	0.0~50.0	0.1	5.0	☆
F6-05	Integration time constant	0.1~100.0s	0.1	10.0	☆
F6-06	Differential Gain	0.0~5.0	0.1	0.0	☆
F6-08	Preset frequency	0.0~100.0% upper limit frequency	0.1	50.0	☆
F6-09	Preset frequency holding time	0.0 ~ 3000.0S	0.1	0.0	☆
F6-10	Feedback disconnection detection threshold	0.0 ~ 100.0%	0.1	5.0	☆
F6-11	Feedback disconnection judgment time	0.0~3000.0s, 0.0 means not perform disconnect judge.	0.1	0.0	☆
F6-12	PID limited negative output	0~100.0%	0.1	0.0	☆
F6-13	Twice the maximum output deviation	0.00~100.00%	0.01	1.00	☆

## 7.8 F7 group parameters for multi-speed and simple PLC control

Code	Name	Description	Unit	Default setting	Property
F7-00	Programmable multi segment speed running setting	Unit' digit: 0: Single segment running finished stop 1: Single segment running finished and keep the finial setting 2: cycle running continue Ten' s digit 0: Running time unit is second 1: Running time unit is minute Hundred's digit: Reserve Thousand's digit: restart selection 0: Every restart from 0 segment point 1: Every restart from break off point frequency.	1	2	×
F7-01	Multi-speed frequency 0	0.0 ~ 100.0%	0.1	10.0	☆
F7-02	Multi-speed frequency 1	0.0 ~ 100.0%	0.1	20.0	☆
F7-03	Multi-speed frequency 2	0.0 ~ 100.0%	0.1	30.0	☆
F7-04	Multi-speed frequency 3	0.0 ~ 100.0%	0.1	40.0	☆
F7-05	Multi-speed frequency 4	0.0 ~ 100.0%	0.1	50.0	☆
F7-06	Multi-speed frequency 5	0.0 ~ 100.0%	0.1	70.0	☆
F7-07	Multi-speed frequency 6	0.0 ~ 100.0%	0.1	80.0	☆
F7-08	Multi-speed frequency 7	0.0 ~ 100.0%	0.1	100.0	☆
F7-09	Multi-speed frequency 8	0.0 ~ 100.0%	0.1	10.0	☆
F7-10	Multi-speed frequency 9	0.0 ~ 100.0%	0.1	20.0	☆
F7-11	Multi-speed frequency 10	0.0 ~ 100.0%	0.1	30.0	☆
F7-12	Multi-speed frequency 11	0.0 ~ 100.0%	0.1	40.0	☆
F7-13	Multi-speed frequency 12	0.0 ~ 100.0%	0.1	50.0	☆
F7-14	Multi-speed frequency 13	0.0 ~ 100.0%	0.1	70.0	☆
F7-15	Multi-speed frequency 14	0.0 ~ 100.0%	0.1	80.0	☆
F7-16	Multi-speed frequency 15	0.0 ~ 100.0%	0.1	100.0	☆
F7-17	Speed 0 running time	0.0 ~ 3000.0	0.1	10.0	☆
F7-18	Speed 0 running direction and acceleration/deceleration	Unit's digit: 0: Forward 1: Reverse Ten' s digit: 0: Acceleration/deceleration 1 1: Acceleration/deceleration 2 2: Acceleration/deceleration 3 3: Acceleration/deceleration 4	1	0	☆
F7-19	Speed 1 running time	0.0~3000.0	0.1	10.0	☆
F7-20	Speed 1 running direction and acceleration/deceleration	As same as speed 1 description	1	0	☆
F7-21	Speed 2 running time	0.0~3000.0	0.1	10.0	☆
F7-22	Speed 2 running direction and acceleration/deceleration	As same as speed 1 description	1	0	☆

Code	Name	Description	Unit	Default setting	Property
F7-23	Speed 3 running time	0.0~3000.0	0.1	10.0	☆
F7-24	Speed 3 running direction and acceleration/deceleration	As same as speed 1 description	1	0	☆
F7-25	Speed 4 running time	0.0~3000.0	0.1	10.0	☆
F7-26	Speed 4 running direction and acceleration/deceleration	As same as speed 1 description	1	0	☆
F7-27	Speed 5 running time	0.0~3000.0	0.1	10.0	☆
F7-28	Speed 5 running direction and acceleration/deceleration	As same as speed 1 description	1	0	☆
F7-29	Speed 6 running time	0.0~3000.0	0.1	10.0	☆
F7-30	Speed 6 running direction and acceleration/deceleration	As same as speed 1 description	1	0	☆
F7-31	Speed 7 running time	0.0~3000.0	0.1	10.0	☆
F7-32	Speed 7 running direction and acceleration/deceleration	As same as speed 1 description	1	0	☆
F7-33	Speed 8 running time	0.0~3000.0	0.1	10.0	☆
F7-34	Speed 8 running direction and acceleration/deceleration	As same as speed 1 description	1	0	☆
F7-35	Speed 9 running time	0.0~3000.0	0.1	10.0	☆
F7-36	Speed 9 running direction and acceleration /deceleration	As same as speed 1 description	1	0	☆
F7-37	Speed 10 running time	0.0~3000.0	0.1	10.0	☆
F7-38	Speed 10 running direction and acceleration/deceleration	As same as speed 1 description	1	0	☆
F7-39	Speed 11 running time	0.0~3000.0	0.1	10.0	☆
F7-40	Speed 11 running direction and acceleration/deceleration	As same as speed 1 description	1	0	☆
F7-41	Speed 12 running time	0.0~3000.0	0.1	10.0	☆
F7-42	Speed 12 running direction and acceleration/deceleration	As same as speed 1 description	1	0	☆
F7-43	Speed 13 running time	0.0~3000.0	0.1	10.0	☆
F7-44	Speed 13 running direction and acceleration/deceleration	As same as speed 1 description	1	0	☆
F7-45、	Speed 14 running time	0.0~3000.0	0.1	10.0	☆
F7-46	Speed 14 running direction and acceleration/deceleration	As same as speed 1 description	1	0	☆
F7-47	Speed 15 running time	0.0~3000.0	0.1	10.0	☆
F7-48	Speed 15 running direction and acceleration/deceleration	As same as speed 1 description	1	0	☆

## 7.9 F8 group parameters for communication

Code	Name	Description	Unit	Default setting	Property
F8-00	Baud selection	0: 300bps 1: 600bps 2: 1200bps 3: 2400bps 4: 4800bps 5: 9600bps 6: 19200bps 7: 38400bps	1	5	☆
F8-01	Data format	0: No parity 1: Odd 2: Even parity	1	0	☆
F8-02	Address	0~247 0: Broadcast address does not return data	1	1	☆
F8-03	The machine response delay	0~100ms	1	5	☆
F8-04	Timeout judgment time	0.0~100.0s 0.0 means time out	0.1	0.0	☆
F8-05	Master-Slave Select	0: Slave port 1: Master port	1	0	☆
F8-06	RS485 frequency reference scale factor	0~999.9%	0.1	100.0	☆
F8-07	Writing operation if return data	0: Return 1: No return	1	0	☆

## 7.10 Advanced F9 group parameters

Code	Name	Description	Unit	Default setting	Property
F9-00	Swing frequency amplitude	0.0~100.0%	0.1	0.0	☆
F9-01	Kick frequency amplitude	0.0~50.0%	0.1	0.0	☆
F9-02	Triangular wave rise time	0.1~3600.0s	0.1	5.0	☆
F9-03	Triangular wave fall time	0.1~3600.0s	0.1	5.0	☆
F9-04	Specify the value of the counter	0~65535	1	1000	☆
F9-05	Counter final value	0~65535	1	2000	☆
F9-06	Setting length	0~65535meter	1	1000	☆
F9-07	The number of pulses per meter	0.1~6553.5	0.1	100.0	☆
F9-08	Internal timer timer unit	0.01~99.99s	0.01	1.00	☆
F9-09	internal timer cycle period	1~65535	1	10	☆
F9-10	Setting the running time	0~65535hour	1	65535	☆
F9-11	X1 switch-on delay time	0.0~3600.0S	0.1	0.0	☆
F9-12	X1 off delay time	0.0~3600.0S	0.1	0.0	☆
F9-13	X2 switch-on delay time	0.0~3600.0S	0.1	0.0	☆
F9-14	X2 off delay time	0.0~3600.0S	0.1	0.0	☆
F9-15	X3 switch-on delay time	0.0~3600.0S	0.1	0.0	☆
F9-16	X3 off delay time	0.0~3600.0S	0.1	0.0	☆
F9-17	Y1 output delay time	0.0~3600.0S	0.1	0.0	☆

Code	Name	Description	Unit	Default setting	Property
F9-18	Relay 1 output delay time	0.0~3600.0S	0.1	0.0	☆
F9-19	Relay 2 output delay time	Relay 1 output delay time	0.1	0.0	☆

### 7.11 FA Enhanced parameter group

Code	Name	Description	Unit	Default setting	Property
FA-00	VF separation mode	0: no separation 1: half separation 2: full separation	1	1	×
FA-01	Voltage source select	0: FA-02 1: AI1 2: AI2 3: Keyboard potentiometer 4: PID 5 AI1+PID	1	0	☆
FA-02	Voltage setting	0~100.0%rated voltage	0.1	0.0	☆
FA-03	Voltage up-down time	0.1~3600.0S	0.1	0.1	☆
FA-06	UP/DW setting value Stop reset	0: no stop reset 1: stop reset	0	0	☆
FA-07	Frequency accuracy	0: 0.01Hz 1: 0.1Hz	1	0	×

### 7.12 Fb Enhanced PID parameter group

Code	Name	Description	Unit	Default setting	Property
Fb-00	Distance pressure gauges range	0.001~60.000MPa	0.001	1.600	☆
Fb-01	Pressure setting	0.001~20.000MPa	0.001	0.500	☆
Fb-02	UP/DW setting value automatic storage	0: no storage 1: storage	1	0	×
Fb-03	Sleeping frequency	0.00~600.00Hz	0.01	0.00	☆
Fb-04	Sleeping delay time	0.0~3000.0S	0.1	60.0	☆
Fb-05	Wake up the pressure	00.0~100.0%	0.1	0.0	☆
Fb-06	Waking up delay time	0.0~3000.0S	0.1	0.5	☆
Fb-07	Under load protect value	0.0~100.0% 0.0: no protect	0.1	0.0	×
Fb-08	Under load protect delay time	0.0~600.0S	0.1	20.0	×
Fb-09	PID parameter select	0: the first group parameter 1: determined by X terminal 2: determined by PID error 3: determined by frequency	1	0	×
Fb-10	The 2 <sup>nd</sup> proportional gain	0.0~50.0	0.1	5.0	☆
Fb-11	The 2 <sup>nd</sup> integration time	0.1~100.0S	0.1	10.0	☆
Fb-12	The 2 <sup>nd</sup> differential gain	0.0~5.0	0.0	0.0	☆
Fb-13	PID parameter switching deviation1	0.0~100.0%	0.1	20.0	☆
Fb-14	PID parameter switching deviation2	0.0~100.0%	0.1	80.0	☆

Code	Name	Description	Unit	Default setting	Property
Fb-15	PID parameter switching frequency1	0.0~100.0% F0-08	0.1	20.0	☆
Fb-16	PID parameter switching frequency 2	0.0~100.0% F0-08	0.1	80.0	☆

### 7.13 Synchronous motor control group (FC)

Code	Name	Description	Unit	Default setting	Property
FC-06	Whether field weakening control	0: No field weakening 1: Field weakening control	1	0	×
FC-07	Whether the maximum torque control MPTA	0: No 1: Perform maximum torque control	1	0	×
FC-08	initial position detection	0: No detection 1: Detection	1	0	×
FC-09	Permanent magnet synchronous motor low frequency mode	0: Mode 0 1: Mode 1	1	0	×
FC-11	Minimum operating frequency of permanent magnet synchronous	0.00~100.00	0.01	2.00	×
FC-15	Maximum field weakening current	0.00~100.00% of rated motor current	0.01	40.00	×
FC-16	Speed Observation Gain 1	0~650.00	0.01	4.00	×
FC-17	Speed Observation Gain 2	0~650.00	0.01	4.00	×
FC-18	Speed observation filter times	1~1000	1	4	×
FC-20	MTPA correction factor	0.0~100.0	0.1	20.0	☆
FC-21	Carrier switching frequency 1	0~100.00Hz, if the output frequency is lower than this value, the carrier of the inverter is FC-23.	0.01	2.00	☆
FC-22	Carrier switching frequency 2	0~300.00Hz, if the output frequency is higher than this value, the inverter carrier is F0-14.	0.01	4.00	☆
FC-23	low frequency carrier	1.0~10.0KHz	0.1	2.0	×
FC-24	Initial position detection coefficient	100~5000	1	1000	×

### 7.14 Fd group parameters for protection

Code	Name	Description	Unit	Default setting	Property
Fd-00	Current limit value	100.0~200.0%	0.1	*	☆
Fd-01	Frequency drop time when over current	1.0~200.0s	0.1	5.0	☆
Fd-02	Over voltage limit	110.0~145.0%	1	130.0	☆
Fd-03	Over voltage suppression gain	0~10	1	2	☆

Code	Name	Description	Unit	Default setting	Property
Fd-04	Phase loss protection	Unit's digit: Input phase limit 0: No protection 1: Protection Ten's digit: Output phase limit 0: No protection 1: Protection	1	11	☆
Fd-05	Motor overload protection	115~250% The inverter outputs 110% of the rated current of the motor, which can run for a long time; Output Fd-05 times the rated current of the motor for 1 minute, and report E.OL2.	0.1	200%	☆
Fd-06	Pre-alarm value of over torque	20.0~200.0%	0.1	*	☆
Fd-07	Over torque detect delay time	0.0~60.0s	0.1	0.1	☆
Fd-08	Fault auto reset times	0~5	1	0	☆
Fd-09	Failure self-reset interval time	0.1~600.0s	0.1	1.0	☆
Fd-10	Fault relay output during reset	0: No output 1: Output	1	0	☆
Fd-11	AI1 input voltage low limit	0.00~10.00V	0.01	2.00	☆
Fd-12	AI1input voltage upper limit	0.00~11.00V	0.01	8.00	☆
Fd-13	Module temperature reaches	25.0~90.0℃	0.1	70.0	☆
Fd-14	Previous two faults	0~30	1	0	×
Fd-15	Previous faults	0~30	1	0	×
Fd-16	Current fault	0~30	1	0	×
Fd-17	Output frequency at current fault	0 ~Upper limit frequency	0.01	0.00	×
Fd-18	Output current at current fault	0 ~ 3000.0A	0.1	0.0	×
Fd-19	DC bus voltage at current fault	0 ~ 900V	1	0	×

### 7.15 A5 group parameters for solar pump control

Code	Name	Description	Unit	Default setting	Property
A5-00	Select solar pump control mode	0: Variable frequency drive control ( AC grid input) 1: CVT (constant voltage tracking) 2: MPPT ( maximum power point tracking )	1	2	×
A5-01	Auto run selection	0: Manual by keypad control 1: Automatically running	1	0	☆
A5-02	CVT object voltage	0.0~100.0% of Voc	0.1	83.0	☆
A5-03	MPPT upper limit voltage	0.0~200.0% of Voc	0.1	200.0	☆
A5-04	MPPT lower limit voltage	0.0~100.0% of Voc	0.1	65.0	☆

Code	Name	Description	Unit	Default setting	Property
A5-05	Frequency adjust gain	1~1000	1	40	☆
A5-06	Frequency adjusting allowable deviation	1~5	1	2	☆
A5-07	MPPT Control period	0.01~10.00S	0.01	1.00	×
A5-08	Dc current correction offset	0.00~50.00A	0.01	0.00	☆
A5-09	Dc current correction gain	0.0~100.0%	0.1	100.0	☆
A5-10	Water level detect control	0: Disable 1: AI1 takes as water level detect signal 2: AI2 takes as water level detect signal Only A5-10 not 0 set, the A5-11 to A5-14 is enable	1	0	☆
A5-11	Water level threshold	0.0~100.0%	0.1	25.0	☆
A5-12	Full water delay	0.0~3000.0S If the detected water level less than A5-11, and lasting for A5-12 delay time. It will give out water full alarm and display A.Ful, and go to sleep. If the time is not reached, the signal is bigger than water level threshold, the time will be reset automatically.	0.1	60.0	☆
A5-13	Empty water delay	0.0~3000.0S After full water level alarmed, if the detected valued greater than A5-11, and lasting more than A5-13 delay time, system restore to running state from sleep mode.	0.1	600.0	☆
A5-14	Hydraulic detection probe damage threshold	0.0~100.0% 0.0: No detected If the detected water level signal large than A5-14, the solar pump drive consider water probe is damaged and sent alarm directly and go to sleep.	0.1	0.0	☆

### 7.16 A6 group parameters for solar pump protection and monitoring

Code	Name	Description	Unit	Default setting	Property
A6-00	Sleep voltage threshold	0~1000V	1	*	☆
A6-01	Restore running state voltage threshold	0~1000V	1	*	☆
A6-02	Awake waiting time	0.0~3000.0S	0.1	120.0	☆

Code	Name	Description	Unit	Default setting	Property
A6-03	Stop frequency when low speed	0.00~300.00Hz	0.01	10.00	☆
A6-04	Stop delay time when reach stop frequency	0.0~3000.0S	0.1	30.0	☆
A6-05	Automatic recovery time in stop frequency protection mode	0.0~3000.0S	0.1	120.0	☆
A6-06	Dry run protection current threshold (under-load protection)	0.0~100.0A	0.1	0.0	☆
A6-07	Dry run detect delay time	0.0~3000.0S	0.1	15.0	☆
A6-08	Automatic recover time in dry run protection mode	0.0~3000.0S	0.1	120.0	☆
A6-09	Motor over current protection threshold	0~3000.0A	0.1	*	☆
A6-10	Over current detect delay time	0.0~3000.0S	0.1	30.0	☆
A6-11	Automatic recovery time in over current protection mode	0.0~3000.0S	0.1	30.0	☆
A6-12	Minimum power input protection threshold	0.00~100.00KW	0.01	0.00	☆
A6-13	Minimum power input detect delay time	0.0~3000.0S	0.1	10.0	☆
A6-14	Automatic recovery time in minimum power input protection mode	0.0~3000.0S	0.1	10.0	☆
A6-15	Alarm action mode	0: Sending alarm and automatically rest 1: Reset by manual Unit's digit: Low stop frequency Ten's digit: Dry run (under load) Hundred's digit: Motor over current protection Thousand's digit: Minimum power input protection	1	0000	☆
A6-16	PQ CURVE P0 (Input power of pump at point 0)	0.00~300.00KW	0.01	0.50	☆
A6-17	PQ CURVE P1 (Input power of pump at point 1)	0.00~300.00KW	0.01	1.00	☆
A6-18	PQ CURVE P2 (Input power of pump at point 2)	0.00~300.00KW	0.01	1.50	☆
A6-19	PQ CURVE P3 (Input power of pump at point 3)	0.00~300.00KW	0.01	2.00	☆
A6-20	PQ CURVE P4 (Input power of pump at point 4)	0.00~300.00KW	0.01	2.50	☆
A6-21	PQ CURVE Q 0 (Flow rate at point 0)	0.0~3000.0m³/h	0.1	0.0	☆

Code	Name	Description	Unit	Default setting	Property
A6-22	PQ CURVE Q 1 (Flow rate at point 1)	0.0~3000.0m <sup>3</sup> /h	0.1	5.0	☆
A6-23	PQ CURVE Q 2 (Flow rate at points 2)	0.0~3000.0m <sup>3</sup> /h	0.1	10.0	☆
A6-24	PQ CURVE Q 3 (Flow rate at point 3)	0.0~3000.0m <sup>3</sup> /h	0.1	15.0	☆
A6-25	PQ CURVE Q 4 (Flow rate at point 4)	0.0~3000.0m <sup>3</sup> /h	0.1	20.0	☆
A6-26	Dry protect frequency	0.00~400.00Hz When the frequency is higher than this value, the dry judgment is made	0.01	45.00	☆
A6-27	Flow measured offset	0.00~1000.0m <sup>3</sup> /h	0.1	0.0	☆
A6-28	Flow measured gain	0.0~100.0%	0.1	100.0	☆
A6-29	Cumulative flow/ generated energy reset setting	0: No operation 1: Flow reset 2: Generated energy reset 3: Both flow and generated energy reset	0	0	×
A6-41	If AI1 as PV current input	1: Yes	1	0	☆
A6-42	What current Corresponds to AI1 10V	0.0~6000.0A	0.1	0.0	×

### 7.17 A7 group parameters for supplementary solar pump control

Code	Name	Description	Unit	Default setting	Property
A7-00	Open circuit voltage (Voc) detect mode	0: Self detect when power on 1: Set by user with A7-01 value	1	1	×
A7-01	User Voc setting by manual	0~1000	1	*	×
A7-02	Response time for solar pump control	0.1~6000.0S	0.1	*	☆
A7-03	Pump efficiency	0.1~100.0%	1	100.0	☆
A7-04	Power display filter time	0.01~100.00S	1	2.00	☆
A7-05	Single phase pump control method.	0: Normal control with starting capacitance 1: Control method without starting capacitance. The connection method: U,W: L1 L2 (the leading out terminals of single phase motor winding) V: N ( the terminal of the two winding connection point)	1	0	×

Code	Name	Description	Unit	Default setting	Property
A7-06	Auxiliary winding coefficient	0.1~500.0%	0.1	100.0	×
A7-08	Float ball alarm (A.Fb.C and A.Fb.o) selfreset delay time	0.1~6000.0S	0.1	300.0	☆

### 7.18 D Group parameters for working status monitor

**Note:** Press shift button of keypad can display output current, output frequency, output voltage, DC bus voltage, DC bus current and input power 6 parameters in circulation in monitor status.

Monitor code	Contents	Mini. Unit
d-00	Current output frequency	0.01Hz
d-01	Current output voltage	1V
d-02	Current output current	0.1A
d-03	Current frequency reference	0.01Hz
d-04	Current output frequency 2	0.01Hz
d-05	DC bus voltage value	1V
d-06	Module temperature	0.1℃
d-07	PID reference value	0.1%
d-08	PID feedback	0.1%
d-09	Speed	rmp
d-10	Running liner frequency	0.01*
d-11	External pulse train input	0.01KHz
d-12	RS485 reference	
d-13	Reserve	
d-14	AI1	0.1V
d-15	AI2	0.1V
d-16	DI terminals status	
d-17	DO terminals status	
d-18	Single continuous run time	1H
d-19	Total running time	1H
d-20	External pulse count value	
d-21	Internal timer count	
d-22	Actual length	m
d-23	Pressure reference	MPa
d-24	Actual pressure	MPa
d-25	Open circuit voltage	1V
d-26	DC bus current	0.01A
d-27	MPPT tracking voltage	0.1%
d-28	Calculate flow rate	0.1m <sup>3</sup> /h

Monitor code	Contents	Mini. Unit
d-29	Today flow	0.1m3
d-30	Cumulative flow 1	0.1m3
d-31	Cumulative flow 2	1Km3
d-32	Input power	0.01KW
d-33	Today generated energy	0.1KWH
d-34	Cumulative generated energy 1	0.1KWH
d-35	Cumulative generated energy 2	1MWH
d-36	Working status	1
d-49	PV Power of AI1 sampling	0.01KW
d-50	AI1 sampling generated energy 1	0.1KWH
d-51	AI1 sampling generated energy 2	1MWH
d-52	AC Power (d-32 - d-49)	0.01KW
d-53	AC generated energy 1	0.1KWH
d-54	AC generated energy 2	1MWH
d-55	PV current of AI1 sampling	0.1A

1) Input terminals status description: The last three to five digital display digital input status.

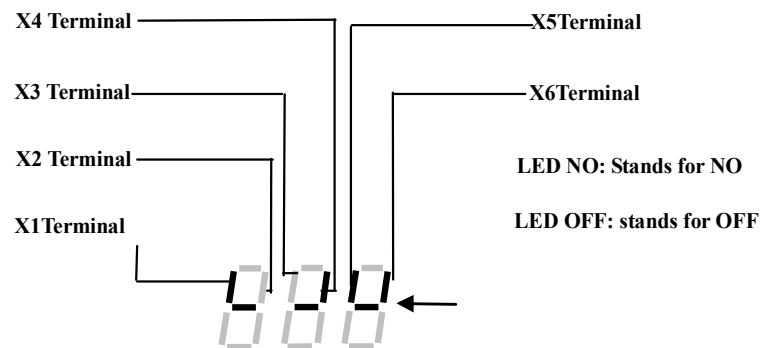

2) DO Terminals status: The lowest bit stands for Y, the second bit stands for relay output 1, the high bit stands for relay output 2.

Y is the lowest position, the output relay 1 followed by 2 relay outputs as a binary number consisting of the highest level, is converted into a decimal display.

3) d-36 working status display introduction:

0: Stop mode

1: Running

2: A.Luo means on low voltage sleep mode ,

3: A.LFr means on low stop frequency sleep mode,

4:A.LCr means on dry run protection

5: A.OCr means on motor over current mode,

6: A.Lpr means on minimum power input mode,

7: A.FuL water full sleep mode.

## Chapter 8. Parameters description in detail

### 8.1 A5 group parameters for solar pump control

A5-00	Select solar pump control mode	0: Variable frequency drive control ( AC grid input) 1: CVT ( constant voltage tracking) 2: MPPT ( maximum power point tracking )
A5-01	Auto run selection	0: No run every time power on when keypad control (F0-02=0) 1: Auto run every time power on when keypad control (F0-02=0)

A5-00 parameter is used to select AC drive variable frequency control mode or solar pump control. There are two solar pump control modes, which are constant voltage tracking (CVT) and maximum power point tracking (MPPT). MPPT solar pump control mode is default setting.

In very good sunlight radiation area, user can select CVT mode for better frequency stable output, because the DC bus voltage is control target in this mode. A5-02 (CVT object voltage) is used to set target control voltage of DC bus. The suggest value setting is 75% to 90%.

A5-01 Auto run selection is used to set auto run every time power on when keypad control (F0-02=0). In the first time using after installation, suggesting select A5-01 for 0, drive control by manual with keypad. Once the commissioning is finished and tested well, we can switch to auto terminal control (F0-02=1) or to auto run every time power on when keypad control (A5-01=1).

In the auto terminal control mode, one programmable digital terminal from X1 to X5 should set for 1 (forward running control).

Compare to F0-02 parameter setting, this parameter has priority level, and make F5-16 and F5-20 set to 1 (FWD running control) as the same time.

Once X1 short circuit to COM (X1 and COM is ON) or X5 short circuit COM (X5 and COM is ON), the drive system will be work automatically.

A5-02	CVT object voltage	0.0~100.0% of Voc
A5-03	MPPT control upper limit voltage	0.0~200.0% open loop circuit voltage
A5-04	MPPT control lower limit voltage	0.0~100.0% open loop circuit voltage
A5-05	Frequency adjusting gain	1~1000
A5-06	Frequency adjusting allowable deviation	1~5
A5-07	MPPT Control period	0.01~10.00S

Uses A5-03 and A5-04 to define MPPT upper limit and lower limit voltage. In generally, the default setting 65% to 200% is OK.

A5-05 (Frequency adjusting gain) parameter is used for making MPPT performance quick or slow during operation. If this value is big, the MPPT performance is quickly, and might cause the output frequency a little fluctuation. if this value is set too small, and might cause A.Luo fault in bad sunlight condition. User can set this value bigger, but not larger than 200 in good sunlight condition area. In generally, the default 40 setting is OK.

A5-06 (Frequency adjusting allowable deviation), change this parameters will effect output frequency stability with MPPT function. If change it bigger, the output frequency might seem a little fluctuation. In generally, no need change this parameters.

We suggest user modify A5-05 parameter first, and don't changed A5-06 setting in generally case.

A5-07 parameter uses to limit MPPT searching period. No need to modify in generally case.

A5-08	Dc current correction offset	0.00~50.00A
A5-09	Dc current correction gain	0.0~999.9%

A5-08 and A5-09 both parameters are used for correcting DC output current display.

Because the output DC current is calculated by software, it needs parameters to correct it when it is not correct.

A5-10 to A5-14 parameters use to set water tank level detecting, it compatible analog signal input.

## 8.2 A6 group parameters for solar pump protection and monitoring

A6-00	Sleep voltage threshold	0~1000V
A6-01	Restore running state voltage threshold	0~1000V
A6-02	Awake waiting time	0.0~3000.0S

A6-00~A6-02 is used for making solar pump drive go to sleep state when input DC voltage is low, and wakes up automatically when DC bus voltage raises again.

When the DC voltage lower than A6-00 value for a system default time, it will go to stop sleep mode and sent out an alarm with A.Luo code display in the keypad.

When DC bus voltage raises again and higher than A6-01 value for a A6-02 setting time, the drive will recover to running state.

A6-03	Stop frequency when low speed	0.00~300.00Hz
A6-04	Stop delay time when reach stop frequency	0.0~3000.0S
A6-05	Automatic recovery time in stop frequency protection mode	0.0~3000.0S

If the output frequency is lower than A6-03 (stop frequency when low speed) for A6-04 (stop frequency delay time), the solar pump drive will go into stop mode to protection pumps.

After A6-05(automatic recover time), the drive will recover to running status again. If A6-15 (Alarm action mode)unit's digit is 0 in default setting. If A6-15 unit's digit is set to 1, needs to reset it by press STOP/RESET button by manual.

A6-06	Dry run protection current threshold ( under-load protection )	0.0~100.0A
A6-07	Dry run detect delay time	0.0~3000.0S
A6-08	Automatic recover time in dry run protection mode	0.0~3000.0S

If the output current is lower than A6-06 (Dry run current) for A6-07 (dry run detect delay time), the drive will go to dry run protection mode.

After A6-08 (recover time of dry run), the drive will restore to running status if A6-15 (Alarm action mode) ten's digit is 0 in default setting. If A6-15 ten's digit is set to 1, needs to reset it by press STOP/RESET button by manual.

A6-09	Motor over current protection threshold	0~3000.0A
A6-10	Over current detect delay time	0.0~3000.0S
A6-11	Automatic recovery time in over current protection mode	0.0~3000.0S

A6-09 to A6-11 parameters is used for setting motor over current protection.

If the current is bigger than A6-09 for A6-10 time, the drive will go to stop mode for providing motor protection.

After A6-11 recover time, the drive will recover to work again if the hundred's digit of A6-15 set to 0 in default. If A6-15 hundred 's digit is set to 1, need to reset it by press STOP/RESET button by manual.

A6-12	Minimum power input protection threshold	0.00~100.00KW
A6-13	Minimum power input detect delay time	0.0~3000.0S
A6-14	Automatic recovery time in minimum power input protection mode	0.0~3000.0S

A6-12 to A6-15 parameters is used for setting minimum power input power protection.

When the input power from solar panel is lower than A6-13 (minimum power input) for A6-13 time, the drive will be stop.

After A6-14 time, the drive will start working again if thousand's digit of A6-15 set for 0 in default. If A6-15 thousand 's digit is set to 1, need to reset it by press STOP/RESET button by manual.

A6-15	Alarm action mode	0: Sending alarm and automatically rest 1: Reset by manual Unit's digit: Low frequency stop mode Ten's digit: Dry run (under load) Hundred's digit: Motor over current protection Thousand's digit: Minimum power input protection
-------	-------------------	---

A6-15 is used for setting low frequency stop mode, dry run mode, motor over current and minimum input power protection, etc 4 kinds of protection reset mode, automatically or manual.

A6-16 to A6-29 parameters provide flow rate calculation by PQ curve programming.

**Flow calculation**

The flow calculation function provides a reasonably accurate flow calculation method without separate flow meter. The function defines the estimated flow using the pump performance curve and drive actual load. The PQ (power/flow) performance curve enables calculating the flow output from the pump. The performance curve is provided by the pump manufacturer. The user saves five operating points (P,Q) of the performance curve to drive parameters.

**PQ curve**

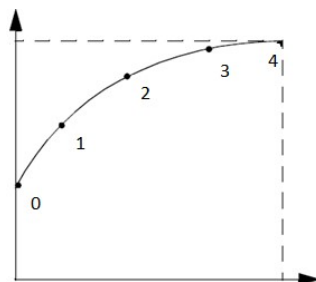

The solar pump drive records and stores the flow rate on each day and provides the required data for current day flow rate and total flow rate.

**Note:**

- Do not use the flow calculation function outside the normal operating range of the pump.

- Do not use the flow calculation function for invoicing purposes.
- Ensure that power and flow points are in incremental order with non-zero values.

A6-16 to A6-20 use to define input power of pump at points 1...5 on the PQ performance curve.

A6-21 to A6-25 use to define flow rate at points 1...5 on the PQ curve respectively.

A6-27	Flow measured offset	0.00~1000.0m <sup>3</sup> /h	0.1	0.0	☆
A6-28	Flow measured gain	0.0~999.9%	0.1	100.0	☆
A6-29	Cumulative flow/generated energy reset setting	0: No operation 1: Flow reset 2: Generated energy reset 3: Both flow and generated energy reset	0	0	×

A6-27 and A6-28 are used for correcting flow calculating for difference pumps.

A6-29 used to cumulative flow and generated energy reset.

## Chapter 9. Troubleshooting and Countermeasures

The below table lists all types of faults of solar pump drive possibly. Before contacting manufacturer for technical support, you can first determine the fault type through following table description and record your treating process and phenomena. If the fault can not be resolved, please seek for the manufacturer service support.

**Troubleshooting table**

Fault code	Fault description	Possible reason	Countermeasures	Value
E. SC	Output short circuit	1: Output short circuit or grounding short circuit 2: The load too heavy	1. Check the output connection 2. seek for service support	1
E. OC1	Over current in acceleration	1. Acceleration time is too short 2. too high torque boost or VF curve setting is not correct	1. Extend the acceleration time 2. low the torque boost voltage, and adjust the V/F curve.	2
E. OC2	Over current in deceleration	The deceleration time is too short	Extend the deceleration time	3
E.OC3	Over current in running	The load changed suddenly or fluctuation is too big	Reduce the load fluctuation	4
E.OC4	Soft ware over current	As same as E.OC1, E.OC2, E.OC3 description	As same as E.OC1, E.OC2, E.OC3	5
E.Gnd	Grounding fault	1: Output grounding of motor or drive 2: Input and output connection of drive	1. Check the connection 2. check the motor if aging or insulation is not good	7
E.OU1	Over voltage in acceleration	1. Input voltage is too high 2. Power supply open and close frequently	Check the Dc input voltage or AC grid condition	8
E. OU2	Over voltage in deceleration	1. Deceleration time is too short 2. Input voltage is abnormal	1. Extend deceleration time 2. Check the input voltage 3. Install braking unit or resistor	9
E.OU3	Over voltage in running	1. Power supply is abnormal 2. load feedback energy	1. Check the voltage of power supply 2. Install braking unit or resistor	10
E.OL1	Over load of drive	1. Load is too big 2. Acceleration is too short 3. Torque boost voltage is high, and VF curve is not properly 4. Input voltage is too low	1. reduce the load or change bigger power drive for instead 2. Extend the acceleration time 3. Low the torque boost voltage, and adjust the V/F curve. 4. Check the grid voltage	15
E.OL2	Motor overload	1. The load is too big 2. Acceleration time is too short 3. Protection coefficient setting is too small 4. Torque boost voltage is high, and VF curve is not properly	1. reduce the load 2. Extend the acceleration time 3. Low the torque boost voltage, and adjust the V/F curve. 4. set the motor protection coefficient bigger	16
E.CUr	Current detect is correct	1. Current detect parts or circuit is problem 2. Auxiliary power supply has problem	Seek for manufacturer support	17
A. Luo	Under voltage	1. Power supply voltage is abnormal 2. power supply is fluctuation	1. check the power supply 2. separate power supply 3. added the solar panel to increase Dc voltage input.	18

<b>Fault code</b>	<b>Fault description</b>	<b>Possible reason</b>	<b>Countermeasures</b>	<b>Value</b>
E.EF1	External equipment normal open terminal fault	External fault input terminal of the drive signal input	Check the signal source and related equipment	19
E.EF2	External equipment normal close terminal fault	External fault input terminal of the drive signal input	Check the signal source and related equipment	20
E.OH	Drive over heat	1. duct obstruction 2. The ambient temperature is too high 3. Fan damage	1. Clean the duct or improved ventilation 2. Reduce the carrier frequency 3. Replace the fan	21
E.SP1	Input phase loss	1. Input voltage phase loss 2. Input voltage is too low	1. Check the connection 2. Check power supply of phase loss	22
E.SP0	Output phase loss	The connection between drive and motor is broken	Check the wiring	23
E.EEP	Memory fault	Hard ware problem	See for support	24
E.End	Running time is reached	The allowable running time setting is reach	Contact vendor	25
E. PID	PID feedback fault	1. PID feedback single is broken 2. sensor has problem 3. feedback signal parameters setting is not correct	1. Check the feedback channel 2. Check whether the fault sensor 3. Verify the feedback signal meets the set requirements	26
E.485	RS485 communication fault	Send and receive data error occurs in serial communication	1. Check the connection 2. Seek for support	27
E.doG	EMC interference	Since the ambient electromagnetic interference caused by malfunction	Install the absorb circuit	28

**Note:**

The series drive records the latest three times fault occurs code and output parameters of drive when latest fault occurs. Query information to help find the cause of the fault.

# Appendix. Solar arrays selecting list.

## Appendix 1. RS485 communication protocol

### A.1 Communication protocol

Solar pump inverter can select the RS485 communication interface. The international standard MODBUS communication protocol is adopted for master-slave communication. The consumer can carry out centralized control by PC/PLC, host computer, main station solar pump inverter etc.

In RTU mode, it always starts after at least 3.5 bytes vacancy time. And next data is: slave machine address, operation command code, data and CRC check. *Every* domain transmission is hexadecimal 0 ...9. A... F.

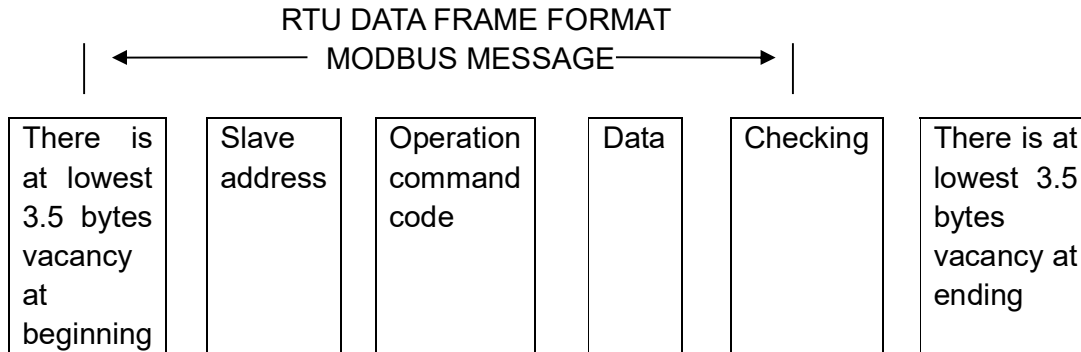

#### RTU frame's standard structure

Frame start	The transmission time of 3.5 bytes in silent
Slave address region	0~247(0 broadcast address )
Operation command code	03H: Read slave parameters 06H: Write slave parameters
Data region DATA(N-1) DATA(0)	The data with 2*N bytes, main content of this part communication, which get from data exchange
CRC CHK low byte	Verification code: CRC verify value
CRC CHK high byte	
Frame end	The transmission time of 3.5 bytes in silent

## A.2 Command code and communication data description

### A.2.1 Command code

Command code: 03H (0000 0011), read N words ( Maximum 5 words can be read)

For example: If the upper controller want to read F0-04 parameters from 01 address drive, see the frame structure as following

#### RTU Host machine order information

Frame start	The transmission time of 3.5 bytes in silent
slave address region	01H
Operation command code	03H

High byte of starting address	F0H
Low byte of starting address	04H
High byte of number of data	00H
Low byte of number of data	01H
CRC CHK low byte	F6H
CRC CHK high byte	CBH
Frame end	The transmission time of 3.5 bytes in silent

#### RTU slave return information

Frame start	The transmission time of 3.5 bytes in silent
slave address region	01H
Operation command code	03H
Bytes of data is read	02H
High byte of F0-04 parameter	00H
Low byte of F0-04 parameter	01H
CRC CHK low byte	79H
CRC CHK high byte	84H
Frame end	The transmission time of 3.5bytes in silent

Command code:06H(000 0110),write a word to address of parameter. For example, write 20.00 to F0-07 of 01H address slave machine. (actual write data is 2000,the corresponding hex data is 7D0H.)

#### RTU host machine command information

Frame start	The transmission time of 3.5bytes in silent
slave address region	01H
Operation command code	06H
High byte of starting address	F0H
Low byte of starting address	07H
High byte of number of data	07H
Low byte of number of data	D0H
Low byte CRC CHK	D0H
High bit CRC CHK	A7H
Frame end	The transmission time of 3.5bytes in silent

#### RTU slave return information

Frame start	The transmission time of 3.5 bytes in silent
slave address region	01H
Operation command code	06H
High byte of starting address	F0H
Low byte of starting address	07H

High byte of number of data	07H
Low byte of number of data	D0H
low byte CRC CHK	08H
High byte CRC CHK	A7H
Frame end	The transmission time of 3.5 bytes in silent

## A2.2 Parameter address

There are two kinds of parameter address representation, such as: FX-YZ parameters can be expressed as FX UV (high front and low in the post, YZ is a decimal representation, UV is a hexadecimal representation of YZ), it can also be expressed as 0X UV. When the operation command 06H, the host computer using the first address of the representation, the written data stored in the E2PROM, using the second address representation, only change the data in RAM, you can reduce the number of operations of E2PROM.

For example ,the corresponding RS485 address of FA-10 is FA 0A

Address explanation other functions

Function Description	Address Definition	Data Meaning Comments	R/W Property
Monitor parameters	1000H 1001H ... 1027H	d-00 d-01 ... d-39	R
Data command	2000H	0000H: Stop 0001H:Forward 0002H: Reverse 0003H: fault reset	W
Running status	3000H	0001H: In forward 0002H: In reverse 0003H: Standby 0004H: In fault	R
Frequency reference	4000H	The percentage corresponding to the upper limit frequency, upper frequency corresponding to 10000	W
Drive fault	5000H	Returns fault number(see Chapter 5)	R

## A2.3 Communication exception

PC either read command (03) or write command (06), an exception may occur at this time, the drive will return an error code.

RTU slave returns an error message

Frame start	3.5bytes transmission time in silent
Slave address region ADDR	xx
Abnormal Tips	86H
Exception code high byte	00
Exception code low byte	0x

CRC CHK low byte	xx
CRC CHK high byte	xx
Frame end	3.5bytes transmission time in silent

Exception code Meaning Description

01H: Invalid command

02H: Invalid address

03H: Invalid Data

04H: CRC error

05H: Parameter cannot be modified

**A2.4 Communication Frame check mode**

Error checking mode frame includes checking two parts, namely byte parity bit (odd / even parity) and the entire frame of data check (CRC check).